

AIR BIKE

OWNER'S MANUAL

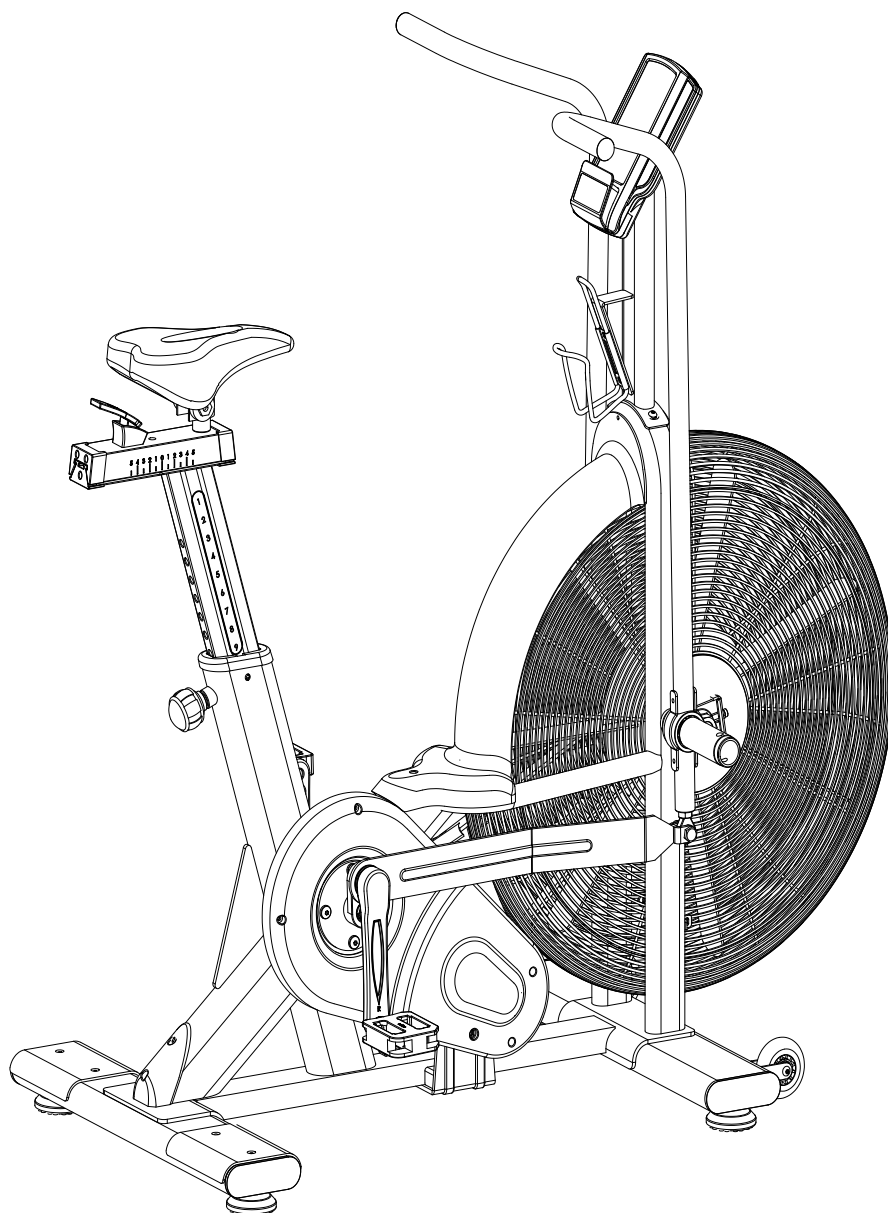

Dear Customer,

Please read this instruction very carefully before using this item. You will find important information regarding safety of your BIKE.

IMPORTANT SAFETY NOTICE

Note the following precaution before assembling or operating the machine.

- 1、 Keep children and pets away from the BIKE at all times.
DO NOT leave unattended children in the same room with the machine.
- 2、 Handicapped or disabled persons should not use the BIKE without the presence of a qualified health professional or physician.
- 3、 If the user experiences dizziness, nausea, chest pain, or any other abnormal symptoms, STOP the workout at once. CONSULT A PHYSICIAN IMMEDIATELY.
- 4、 Before beginning training, remove all within a radius of 2 meters from the machine. DO NOT place any sharp objects around the BIKE.
- 5、 Position the BIKE on a clear, level surface away from water and moisture. Place mat under the unit to help keep the machine stable and to protect the floor.
- 6、 Use the BIKE only for its intended use as described in this manual. DO NOT use any other accessories not recommended by the manufacturer.
- 7、 Assemble the machine exactly as the descriptions in the instruction manual.
- 8、 Check all bolts and other connections before using the machine for the first time and ensure that the trainer is in the safe

condition.

- 9、 Hold a routine inspection of the equipment. Pay special attention to components which are the most susceptible to wear off, i.e. connecting points and wheels. The defective components should be replaced immediately. The safety level of this equipment can only be maintained by doing so. Please don't use the BIKE until it is repaired well.
- 10、 NEVER operate the BIKE if it is not functioning properly.
- 11、 This machine can be used for only one person's training at a time.
- 12、 Do not use abrasive cleaning articles to clean the machine. Remove drops of sweat from the machine immediately after finishing training.
- 13、 Always wear appropriate workout clothing when exercising. Running or aerobic shoes are also required.
- 14、 Before exercising, always do stretching first.
- 15、 The power of the machine increases with increasing the speed, and the reverse. The machine is equipped with adjustable knob, which can adjust the resistance.

WARNING: BEFORE BEGINNING THIS OR ANY EXERCISE PROGRAM, CONSULT YOUR PHYSICIAN F I R S T. THIS IS ESPECIALLY IMPORTANT FOR INDIVIDUALS OVER THE AGE OF 35 OR PERSONS WITH PRE-EXISTING HEALTH PROBLEMS. READ ALL INSTRUCTIONS BEFORE USING THE BIKE. THANE ASSUMES NO RESPONSIBILITY FOR PERSONAL INJURY OR PROPERTY DAMAGE SUSTA I N E D BY OR THROUGH THE USE OF THIS PRODUCT

EXPLODED-VIEW & PARTS LIST:

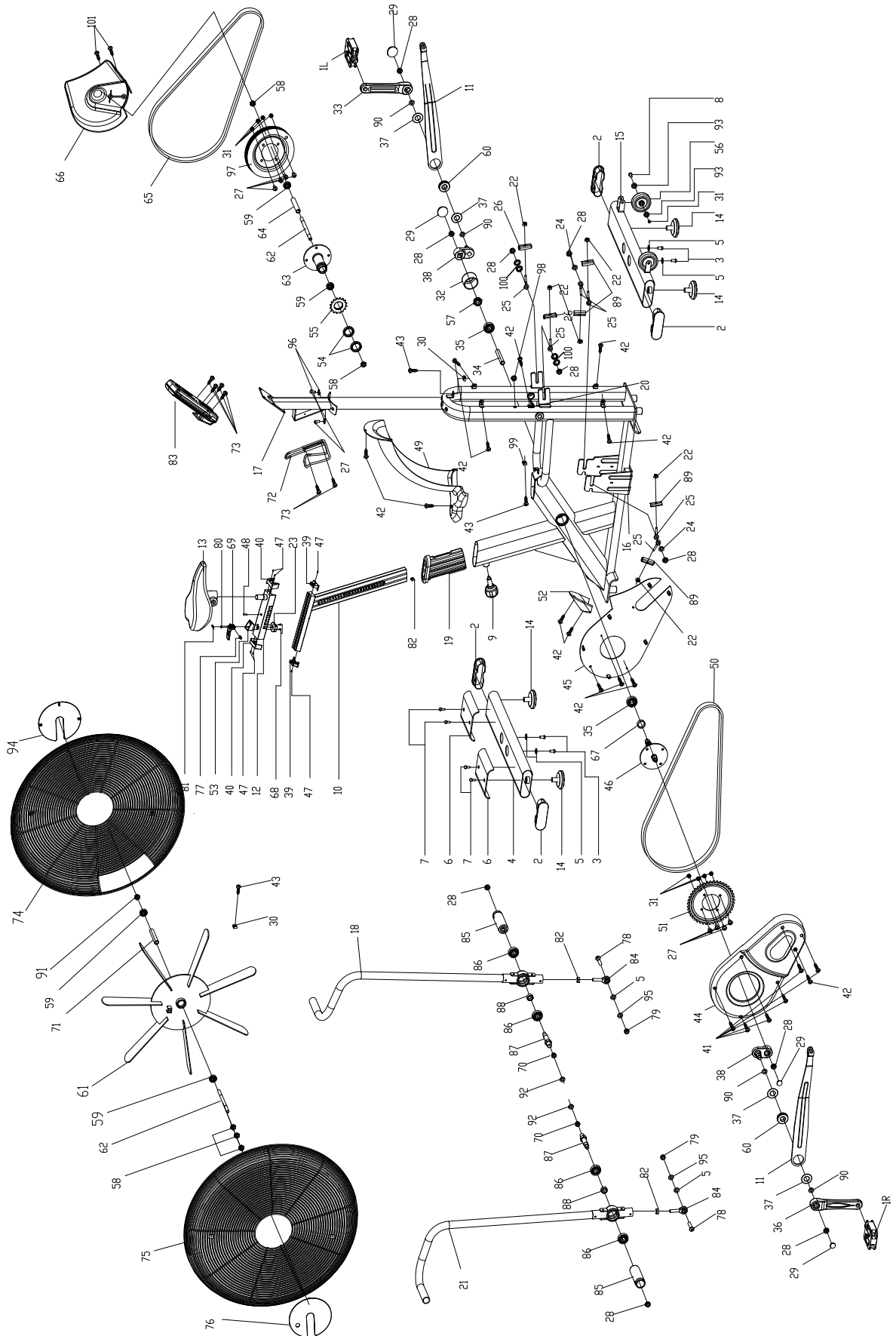

NO	NAME	QUANTITY	SPEC
1	PEDAL	1	JD-304V (9/16")
2	END CAP3	4	120*40*35
3	BOLT 1	4	GB/T 70.2-2000 M10*30
4	REAR STABILIZER	1	WELDING
5	FLAT WASHER	6	GB/T 95-2002 10
6	FRONT COVER	2	160*128*3
7	BOLT 1	4	GB/845-85 ST4.8X19
8	BOLT 2	2	GB/T 5780-2000 M8*40
9	SHAPE KNOB	1	φ50*91 (M16*35)
10	VERTICAL SEAT POST	1	WELDING
11	Drive assembly	2	WELDING
12	SEAT POST	1	WELDING
13	SEAT	1	KS-9068
14	STOPPER	4	φ70*41/(M16X25)
15	FRONT STABILIZER	1	WELDING
16	MAIN FRAME	1	WELDING
17	Electronic watch connecting assembly	1	WELDING
18	The left handlebar assembly	1	WELDING
19	PLASTIC SLEEVE	1	103*53.5*178
20	SENSOR	1	SR-202
21	Right handlebar assembly	1	WELDING
22	NUT	6	GB/T 889.1-2000 M6
23	FIXING NUT 2	1	φ44.8*16.5
24	FLAT WASHER	2	GB/T 95-2002 12 (H=2)
25	FIXING BOLT	2	M6*60
26	Pull out the fixed piece	2	δ1
27	BOLT 1	10	GB/T 70.2-2000 M8*16
28	NUT	10	M12X1.25 H=8MM
29	CRANK END CAP	4	φ28*6.5
30	Sprocket buckle	9	δ1
31	NUT	10	GB/T 889.1-2000 M8
32	PLASTIC RING	1	φ56*28
33	LEFT CRANK	1	170*15
34	LONG FIXING TUBE	1	φ25*φ20.2*41.2
35	BEARING	2	6004ZZ
36	RIGHT CRANK	1	170*15
37	Outer spring	4	42
38	Crank drive assembly	2	80*65
39	COVER	2	56*23.6*24.6
40	COVER	2	58*36.3*22.7
41	SCREW 1	6	GB/T 845-1985 ST4.2*19
42	SCREW 2	16	GB/T 845-1985 ST4.2*19
43	SCREW 3	6	GB/845-85 ST4.8X19
44	CHAIN COVER 1	1	478*270*60
45	CHAIN COVER 2	1	469*241*23
46	AXIS	1	φ20*162
47	BOLT 7	6	GB/T 70.1-2000 M4*12
48	BOLT 8	1	GB/T 70.1-2000 M5*18
49	Sweat proof cover	1	438*194*399
50	SHORT CHAIN WHEEL	1	P=12.7, 66

NO	NAME	QUANTITY	SPEC
51	BELT WHEEL	1	P=12.7,Z=52T
52	FRONT COVER	1	122*56*45
53	Handle base	1	41.5*30*30
54	LOCK NUT	2	M33*1*4
55	CHAIN WHEEL 1	1	A7K-16 1/2"*1/8" 16T (1.37")
56	WHEEL	2	φ75*24
57	FIXING NUT	1	M20*1.0
58	FIXING NUT 2	3	M12X1.25 H=6
59	BEARING	4	6001ZZ
60	BEARING	2	6004ZZ
61	Rim assembly	1	φ640*69
62	FLYWHEEL SHAFT	1	φ12*160
63	Double drive assembly	1	φ110*107
64	Double drive inner sleeve	1	φ16*φ12.2*91.1
65	BELT	1	5PK53
66	CHAIN COVER 3	1	248*269*80
67	SHORT FIXING TUBE	1	φ25*φ20.5*9
68	BOLT 1	2	GB/845-85 M4*12
69	Handle	1	79*32*32.6
70	NUT	2	GB/T 889.1-2000 M16 H=12
71	Flywheel inner casing	1	φ16*φ12.2*53.1
72	BOTTLE HOLDER	1	φ6
73	SCREW 3	6	GB/T 5780-2000 M5*10
74	The left wheel cover	1	φ690*55
75	Right wheel cover	1	φ690*55
76	Fan baffle	1	φ170*10
77	Handle rotary copper sleeve	1	φ12*20
78	BOLT 3	2	M10*50
79	NUT	2	GB/T 889.1-2000 M10 H=15
80	BOLT 16	1	M6*35
81	Handle cover	1	φ16.4*10.3*5.5
82	NUT	2	GB/T 889.1-2000 M14*1.5 H=10mm
83	COMPUTER	1	JSD-10421
84	Universal joint	2	82*30 (M14*1.5)
85	Foot lever	2	φ38*110(M16*1.5)
86	BEARING	4	6203ZZ
87	Foot lever	2	φ22*120(M16*1.5)
88	Foot lever bushing	2	φ24*φ17.2*11.1
89	Small retaining plate	4	δ3
90	corrugated gasket	4	φ20
91	FIXING NUT 1	1	M12X1.25 H=10
92	SPRING WASHER 2	2	GB/T 859-1987 16
93	BEARING	4	608ZZ
94	Fan baffle	1	φ170*10
95	SPRING WASHER	2	GB/T 859-1987 10
96	SPRING WASHER 2	10	GB/T 859-1987 8
97	BELT WHEEL	1	φ200*24
98	Plastic plug	1	φ14*14
99	FIXING BOLT	4	M6*56
100	Serrated gasket	4	GB/T 95-2002 12
101	SCREW 2	2	GB/T 845-1985 ST4.2*25

ASSEMBLY INSTRUCTION:

1.PREPARATION:

- A. Before assembling make sure that you will have enough space around the item.
- B. Use the present tooling for assembling.
- C. Before assembling please check whether all needed parts are available (at the above of this instruction sheet you will find an explosion drawing with all single parts (marked with numbers) which this item consists of.

2.ASSEMBLY INSTRUCTION:

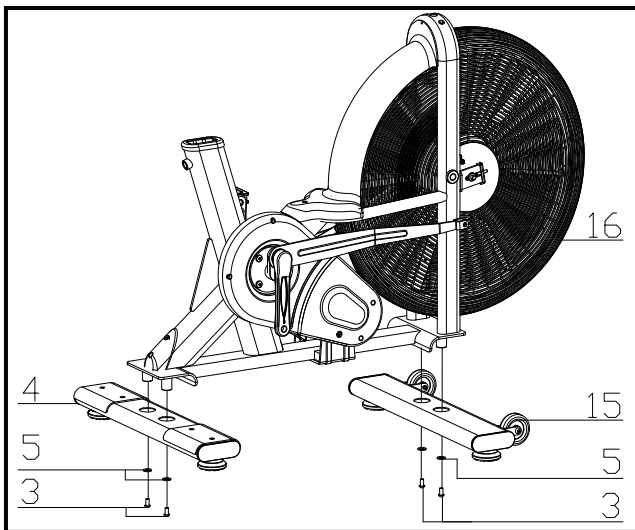

FIG.1

FIG.1:

Attach the Front Stabilizer (pt.15) to the Main Frame (pt.16) using two sets of Ø10 Flat Washers (pt.5) and bolt 1 (3).

Attach the Rear Stabilizer (pt.4) to the Main Frame (pt.16) using two sets of Ø10 Flat Washers (pt.5) and bolt 1 (3)

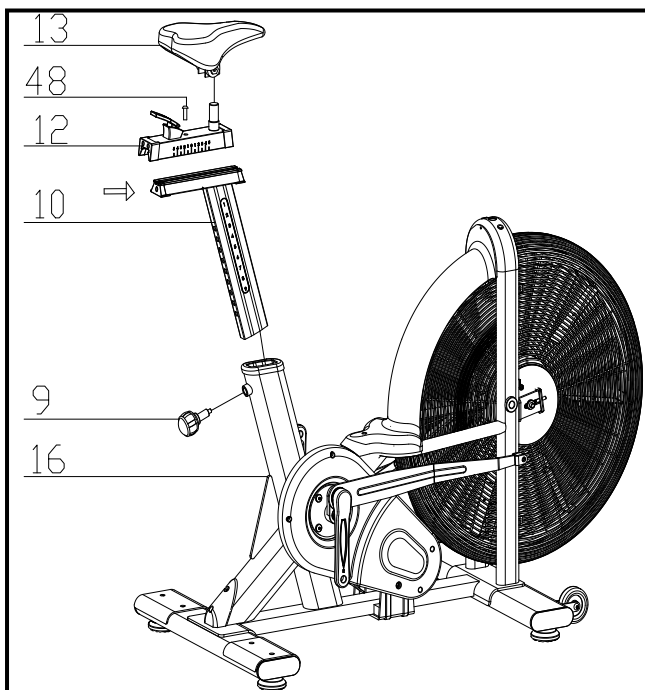

FIG.2

FIG.2:

Slide the Vertical Seat Post (pt.10) into the seat post housing on the main frame (pt.16). And put the knob up, then release the round nut(pt.48) , Then slide the Seat Post (pt.12) into the Vertical Seat Post (pt.10),Then fixing the bolt8 (pt.48), You will have to slacken the knurled section of the Adjustment Knob (pt.9) and pull the knob back and then select the desired height. Release the knob and retighten the knurled portion.

Now fix the Seat (pt.13) to the Seat Post (pt.12) as shown, and tighten the bolts around the screws under the seat.

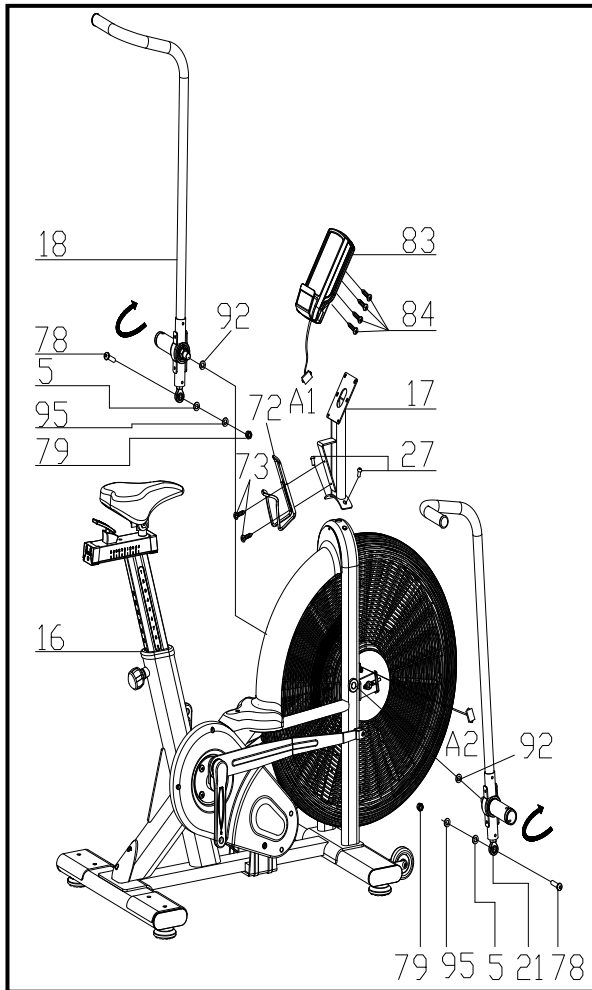

FIG.3

FIG.3:

The left hand assembly (18), the right wrench assembly (21) and the Spring washer (92) are fixed to the main frame assembly (16) in accordance with the graphic method, the inner six angle flat head screws (78), flat washer (5), Spring washer (92), the lock nut (79) drive assembly connected then, locking; electronic connection assembly (17) with six angle flat head screws (27) fixed to the main frame assembly (16), the cross slot screw (73) will Aluminum Alloy kettle (72) fixed to the main frame assembly (16) on, ATTENTION: YOU SHOULD FIX THE HANDLEBAR TIGHTLY

The electronic meter assembly (83) with cross slot screw (84) fixed to the electronic connection assembly (17), connect the plug (A1&A2),

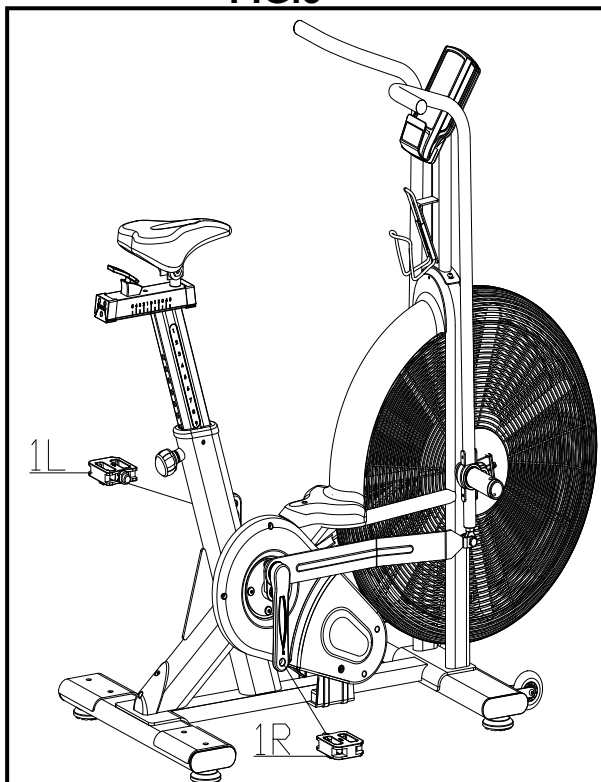

FIG.4

FIG.4:

The Pedals (pt.1 L & pt.1 R) are marked "L" and "R" - Left and Right. Connect them to their appropriate crank arms. The right crank arm is on the right-hand side of the cycle as you sit on it.

Note that the Right pedal should be threaded on clockwise and the Left pedal anticlockwise.

ADJUSTMENT

*To adjust the seat height, slacken the spring knob on the vertical post stem on the main frame and pull back the knob. Position the vertical seat post for the desired height so that holes are aligned, then release the knob and retighten it.

*To move the seat forward in the direction of the handlebar or backwards away from it, loosen the adjusting knob and washer and pull the knob back. Slide horizontal seat post into desired position. Align holes and then retighten the adjusting knob.

*To adjust the handlebar height, slacken the spring knob and secondary knob and pull both knobs back. Slide the handlebar post along the housing on the main frame to the desired height and, with the holes aligned correctly, tighten the spring adjusting knob and then the secondary knob.

EXERCISE INSTRUCTIONS

Using your **BIKE** provides you with several benefits, it will improve your physical fitness, tone muscle and in conjunction with calorie controlled diet help you lose weight.

1.The Warm Up Phase

This stage helps get the blood flowing around the body and the muscles working properly. It will also reduce the risk of cramp and muscle injury. It is advisable to do a few stretching exercises as shown below. Each stretch should be held for approximately 30 seconds, do not force or jerk your muscles into a stretch - if it hurts, **STOP**.

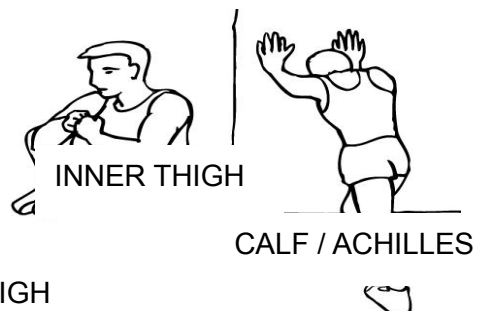
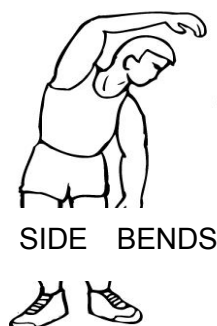

CALF / ACHILLES

2.The Exercise

Phase

This is the stage where you put the effort in. After regular use, the muscles in your legs will become stronger. Work to your limit but it is very important to maintain a steady tempo throughout. The rate of work should be sufficient to raise your heart beat into the target zone shown on the graph below.

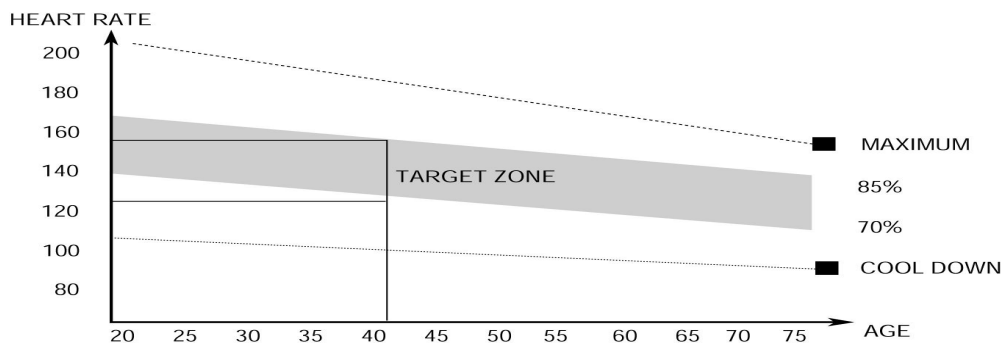

This stage should last for a minimum of 12 minutes for most people

This stage is to let your Cardio-vascular System and muscles wind down. This is a repeat of the warm up exercise e.g. reduce your tempo, continue for approximately 5 minutes. The stretching exercises should now be repeated, again remembering not to force or jerk your muscles into the stretch.

As you get fitter you may need to train longer and harder. It is advisable to train at least three times a week, and if possible space your workouts evenly throughout the week.

MUSCLE TONING

To tone muscle while on your **BIKE** you will need to have the resistance set quite high. This will put more strain on our leg muscles and may mean you cannot train for as long as you would like. If you are also trying to improve your fitness you need to alter your training program. You should train as normal during the warm up and cool down phases, but towards the end of the exercise phase you should increase resistance, making your legs work harder than normal. You may have to reduce your speed to keep your heart rate in the target zone.

WEIGHT LOSS

The important factor here is the amount of effort you put in. The harder and longer you work the more calories you will burn. Effectively this is the same as if you were training to improve your fitness, the difference is the goal.

USE

The tension control knob allows you to alter the resistance of the pedals. A high resistance makes it more difficult to pedal, a low resistance makes it easier. For the best results set the tension while the bike is in use.