

SKIERG USER MANUAL

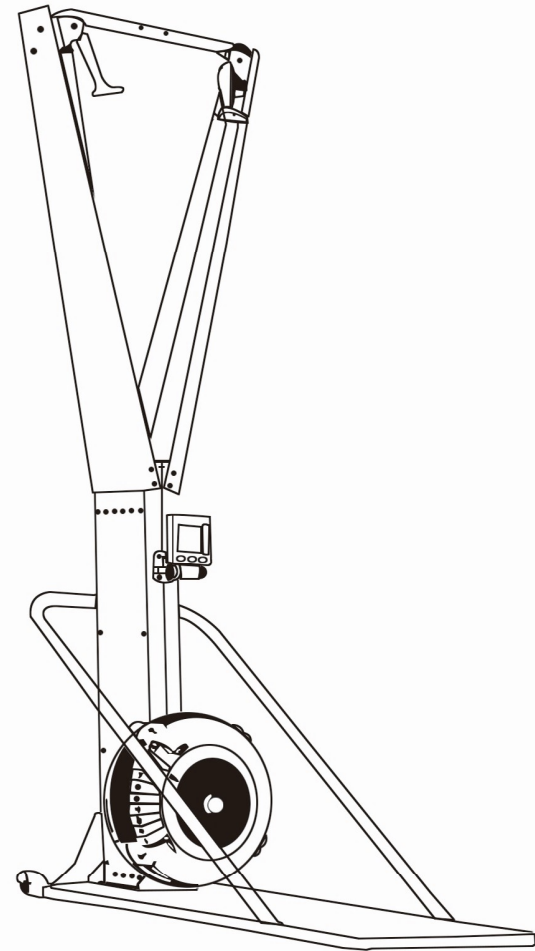

Important - Please read these instructions fully before assembly or using
These instructions contain important information which will help you get the best from
your equipment and ensure safe and correct assembly, use and maintenance.

CONTENTS

| | |
|--------------------------------|----|
| SAFETY INSTRUCTIONS..... | 2 |
| PACKING LIST..... | 3 |
| INSTALLATION GUIDE..... | 5 |
| OPERATION INSTRUCTIONS..... | 9 |
| MAINTENANCE..... | 11 |
| MONITOR BRIEF DESCRIPTION..... | 13 |

SAFETY INSTRUCTIONS

WARNING:

To reduce the risk of serious injury, read all important precautions and instructions in this manual and all warning on your product before using your product. We assume no responsibility for personal injury or property damage sustained by or through the use of this product.

1. Before beginning this or any exercise program, consult your physician. This is especially important for persons over age 35 or persons with pre-existing health problems.
2. Keep children under age 12 and pets away from the product at all times.
3. Never allow more than one person on the product at the same time.
4. If users experience dizziness, nausea, chest pain or other discomfort during training, please stop training immediately and consult a doctor immediately,
5. Place the product on a clean, level floor and do not use near water sources or outdoors.
6. When training, please wear appropriate sportswear. It is strictly prohibited to wear long shirts and other loose clothes that are easily clipped by devices. Running shoes or other sports shoes are recommended.
7. The product must be used in accordance with the operating functions described in the manual, and no other accessories or product functions not recommended by the manufacturer should be used to avoid injury,
8. Do not have obstacles or sharp objects around the product.
9. People with disabilities are not allowed to use the product alone without the supervision of a professional or health care provider.
10. A proper warm-up and stretching exercise must be done before each workout.
11. Please according to their own physical fitness choose the appropriate weight for exercise, it is recommended to adopt a step-by-step approach.
12. Do not use the product without complete functions.

DAILY MAINTENANCE

1. Lubricate moving parts regularly
2. All parts of the product must be inspected and secured before use
3. Use a wet towel and mild detergent to clean the product. Do not use chemical solvents to clean the product

PACKING LIST

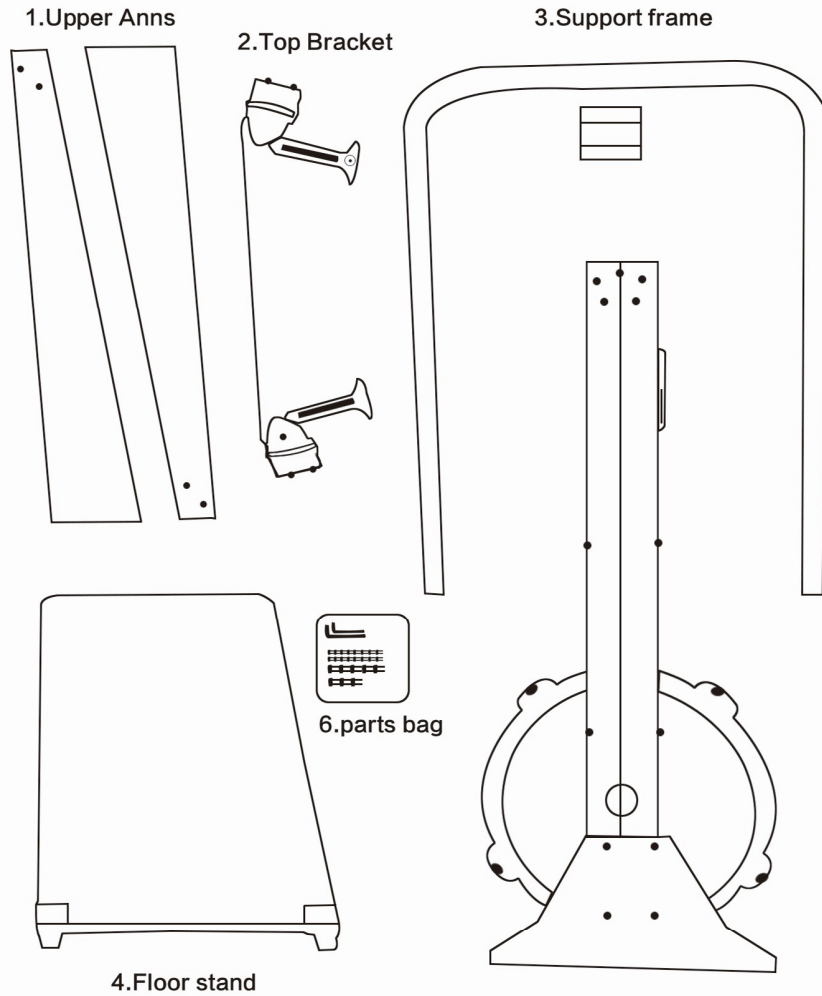

| No | Description | Qty |
|----|---------------------------------------|-----|
| 1 | Upper anns(left&right) | 2 |
| 2 | Top Bracket | 1 |
| 3 | Support frame | 1 |
| 4 | Floor stand | 1 |
| 5 | Body (incildes flywheel and Monitor) | 1 |
| 6 | Parts bag | 1 |
| 7 | 6*10 Screw | 16 |
| | 8*25 Screw | 8 |
| | 5mm Allen wrench | 1 |
| | 4mm Allen wrench | 1 |
| | Screw set | 1 |

INSTALLATION GUIDE

STEP1: INSTALL SUPPORT FRAME AND FLOOR STAND

M8*25 Screw*2

Washer*2

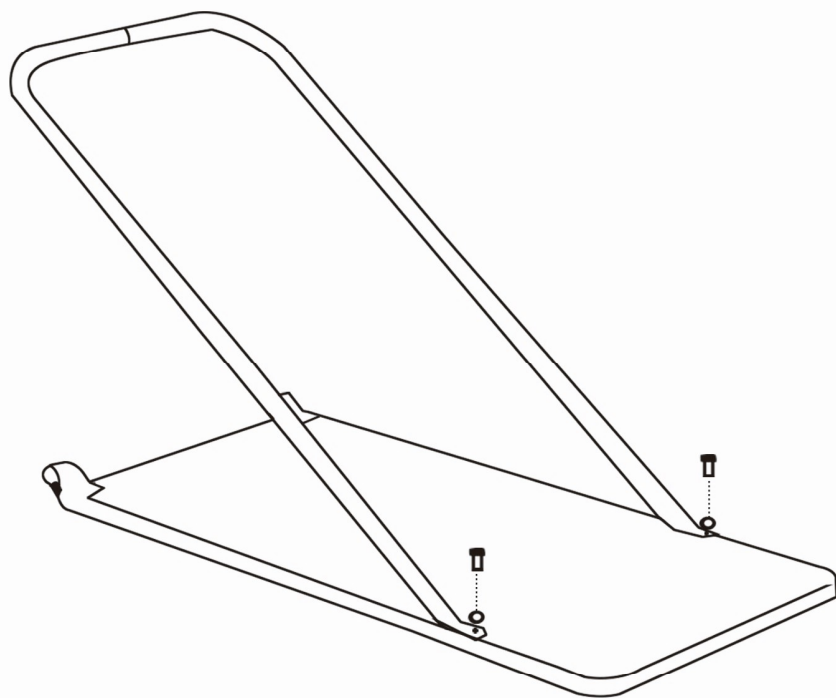

STEP2: INSTALL BODY FLOOR STAND

M8*25 Screw*6

Washer*6

M6*10 Screw*4

Washer*4

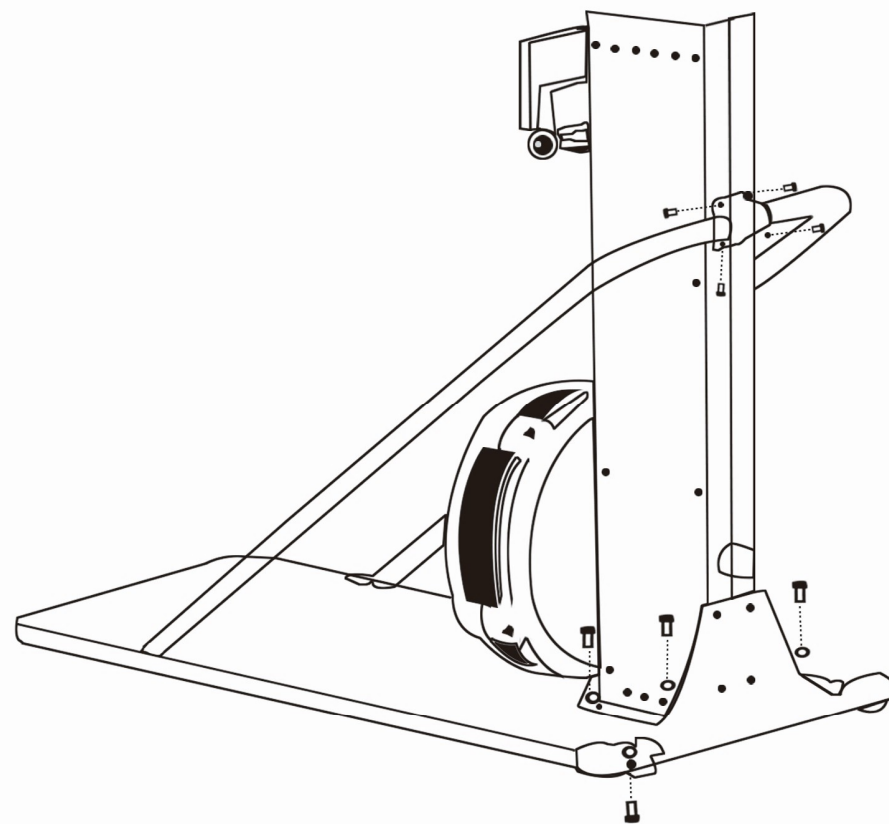

INSTALLATION GUIDE

STEP3:Instill Upper arms(Notice the left and right)

M6*10 screw*8

Washer*8

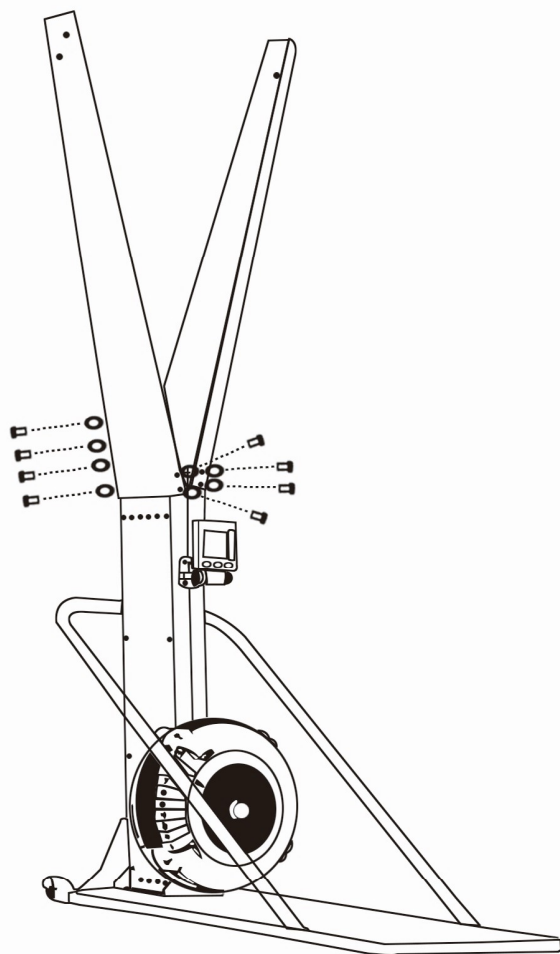

STEP4:Instill Top Bracket

M6*10 screw*4

Washer*4

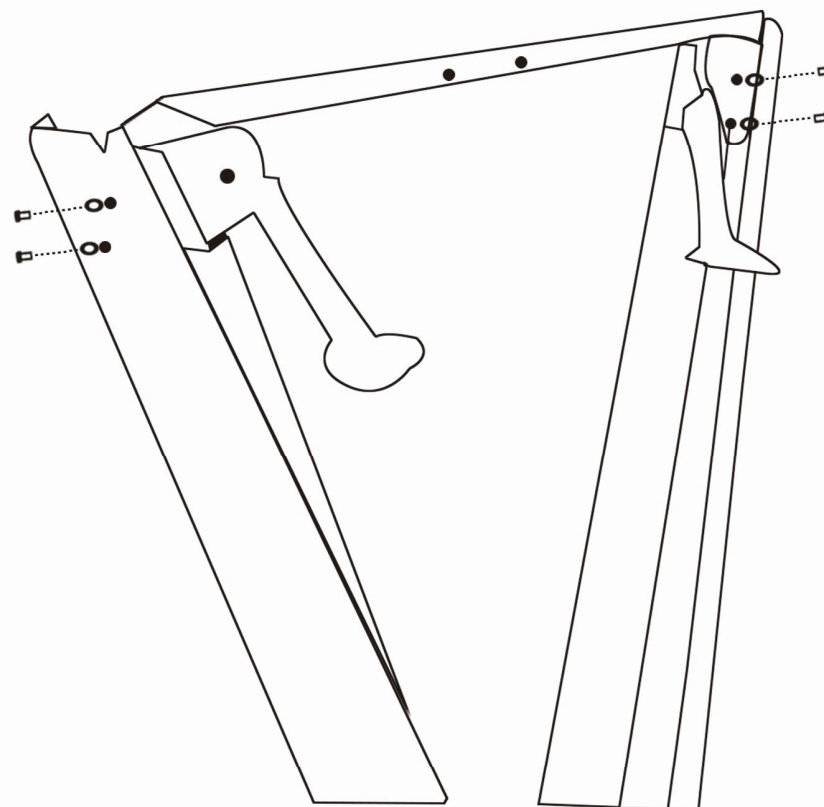

OPERATION INSTRUCTIONS

1. USE & TRAINING

1) Double-Pole Technique

Begin with your hands shoulder-width apart at about eye level. Your arms should be bent. Your feet should be shoulder-width apart.



2) Drive the handles downward by engaging your abdominal muscles and bending your knees. Maintain the bend in your arms to keep the handles fairly close to your face.



3) Finish the drive with knees slightly bent, and arms extended down alongside your thighs.

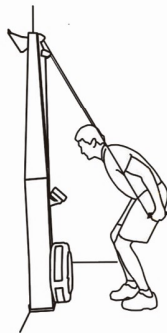

4) Bring your arms back up and straighten your body to return to the start position.



MAINTENANCE

- The bungee cord consists of elastic fibers encased in a braided covering. Some “fuzzing” of the covering is normal, but once the white fibers are exposed the cord should be replaced immediately.

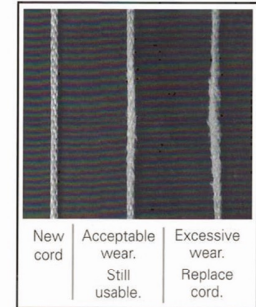

Inspect the fasteners

Be sure all fasteners are tight and have not become loose during use. If your skierg is wall mounted examine the wall mount fasteners carefully.

Inspect the Bracket pulleys

Be sure the pulleys spin freely in the pulley housings and that the pulley housings swing freely in the pulley brackets.

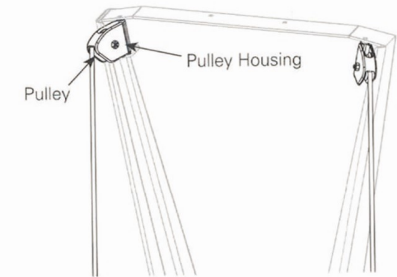

As Needed

- Clean surfaces of the SkiErg, including floor or floor stand base with any non-abrasive household cleaner. DO NOT spray any fluid onto the PM.
- Dust and lint can collect inside of the flywheel enclosure. This buildup can restrict airflow, reducing the resistance of the fan. The outer cover of the enclosure can be removed for cleaning by removing the four screws that hold the cover together. See illustrations.

INSTALLATION GUIDE

Flywheel Opening and Cleaning

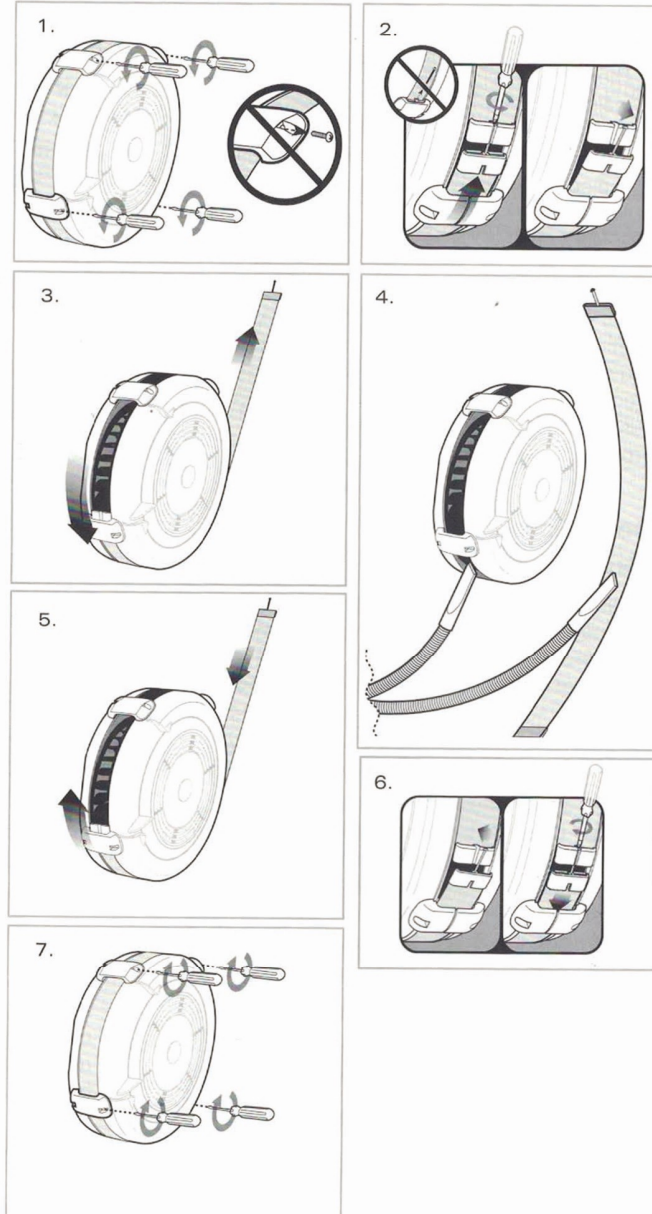

MONITOR BRIEF DESCRIPTION

GETTING STARTED WITH THE MONITOR

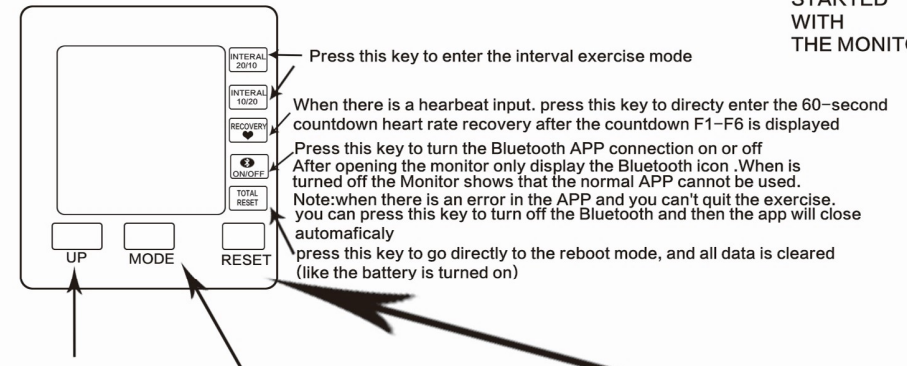

- Press this key to enter the interval exercise mode
 - When there is a heartbeat input, press this key to directly enter the 60-second countdown heart rate recovery after the countdown F1-F6 is displayed
 - Press this key to turn the Bluetooth APP connection on or off. After opening the monitor only display the Bluetooth icon. When is turned off the Monitor shows that the normal APP cannot be used. Note: when there is an error in the APP and you can't quit the exercise, you can press this key to turn off the Bluetooth and then the app will close automatically
 - press this key to go directly to the reboot mode, and all data is cleared (like the battery is turned on)
- A. Press once to increase, long press to increase the setting quickly
 - B. TIME range 0:00-99:00 (INTERVAL function, every adjustment rises 0:01, TIME function every adjustment rises 100)
 - C. CALORIES range :0-9990 (press it to increase CALORIES by 10)
 - D. DISTANCE range 0-9990 (press it to increase DISTANCE by 10)
 - E. STROKES range 0-9990 press it to increase STROKES by 10)
- A. In the function selection mode, press it once to confirm the function
 - B. In the setting mode, press it once to confirm the setting
 - C. In sport mode, press it once to enter pause or start mode
 - D. There will be a beep every time you press the button for 2 seconds to switch DISTANCE units (METER or MILE)
- A. In the function selection mode, each time you press it you will return to the previous level
 - B. In the setting mode press once to clear the current set data
 - C. In the pause mode, press once to return to the standby mode
 - D. There will be a beep every time you press the button
 - E. Long press it 3 seconds to turn on the machine to enter standby mode, MANUAL INTERVAL TARGET, TIME DISTANCE, CALORIE, PULSE, SPM, VATT TOTAL STROKES STROKES cycle through the scan mode for 1 second