

Owner's manual











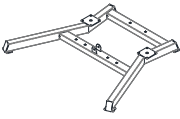
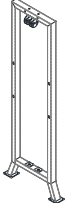
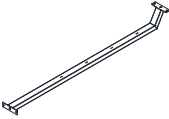
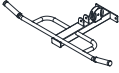
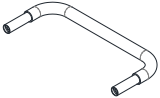
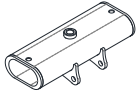
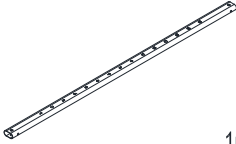

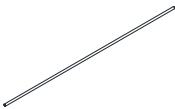



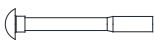









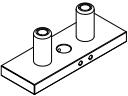
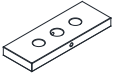

※※※ Pay attention to fixing and operation ※※※

1. Please keep the box and the manual after installing the machine.
2. Checking the stability of the screws regularly.
3. Please install the machine in a commodious place.
4. Putting the machine on the level ground, and use a mat to protect the floor.
5. The machine is fit for the healthy people; please don't use it when you feel uncomfortable.
6. There are slip proof cover on the nut (little nylon circle on the nut); please strengthen them in wrench.
7. The product is only fit for corresponding exercise, please don't do other exercise.
8. Please strengthen the screws; otherwise, it is very dangerous.
9. When there are some dilapidation and distortion, please don't use it.
10. It's very dangerous to change and mend the machine, so it's absolutely forbid.
11. Avoiding use and storage the product on the circumstance such as dampness, high temperature and under sun.

If there are some changes in manner, appearance and so on. Please forgive us not to inform you.

Part List

Key No.	Description	Qty.	Key No.	Description	Qty.
1	Bottom frame	1	21	Φ10 Washer	60
2	Main frame	1	22	M12 Nut	1
3	Rear column	1	23	M10 Nylon Lock Nut	30
4	Pull-up frame	1	24	Wire rope	1
5	Handle	2	25	Magnetic latch	1
6	Sliding tube	1	26	Buffer blocks	2
7	Front column	1	27	Upper Weight piece	1
8	Single pulley seat	1	28	Weight piece	9
9	Pulley seat	2	29	Peg	4
10	Guide rods	2	30	Cross screw	8
11	Pedal	2	31	Selection lever (Pre. - Assembled)	1
12	Low-pull handle	1	32	Pull pins	1
13	M10X120 Hex Bolt	2	33	Pulley	10
14	M10X95 Hex Bolt	4	34	Triceps rope pull	1
15	M10X70 Carriage Bolt	6	35	Handle	1
16	M10X65 Hex Bolt	2	36	Ankle strap	1
17	M10X45 Hex Bolt	8	37	Hook	2
18	M10X30 Hex Bolt	8			
19	M10X25 Hex Bolt	4			
20	M10X20 Hex Bolt	2			

<p>1 Bottom frame</p>  <p>1pc</p>	<p>2 Main frame</p>  <p>1pc</p>	<p>3 Rear column</p>  <p>1pc</p>	<p>4 Pull-up frame</p>  <p>1pc</p>	
<p>5 Handle</p>  <p>2pcs</p>	<p>6 Sliding tube</p>  <p>1pc</p>	<p>7 Front column</p>  <p>1pc</p>	<p>8 Single pulley seat</p>  <p>1pc</p>	
<p>9 Pulley seat</p>  <p>2pcs</p>	<p>10 Guide rods</p>  <p>2pcs</p>	<p>11 Pedal</p>  <p>2pcs</p>	<p>12 Low-pull handle</p>  <p>1pc</p>	
<p>13 M10X120 Hex Bolt</p>  <p>2pcs</p>	<p>14 M10X95 Hex Bolt</p>  <p>4pcs</p>	<p>15 M10X70 Carriage Bolt</p>  <p>4pcs</p>	<p>16 M10X65 Hex Bolt</p>  <p>2pcs</p>	<p>17 M10X45 Hex Bolt</p>  <p>8pcs</p>
<p>18 M10X30 Hex Bolt</p>  <p>8pcs</p>	<p>19 M10X25 Hex Bolt</p>  <p>4pcs</p>	<p>20 M10X20 Hex Bolt</p>  <p>2pcs</p>	<p>21 Φ10 Washer</p>  <p>60pcs</p>	<p>22 M12 Nut</p>  <p>1pc</p>
<p>23 M10 Nylon Lock Nut</p>  <p>30pcs</p>	<p>24 Wire rope</p>  <p>1pc</p>	<p>25 Magnetic latch</p>  <p>1pc</p>	<p>26 Buffer blocks</p>  <p>2pcs</p>	
<p>27 Upper Weight piece</p>  <p>1pc</p>	<p>28 Weight piece</p>  <p>11pcs</p>	<p>29 Peg</p>  <p>4pcs</p>	<p>30 Cross screw</p>  <p>8pcs</p>	
<p>31 Selection lever(Pre- Assembled)</p>  <p>1pc</p>	<p>32 Pull pins</p>  <p>1pc</p>	<p>33 Pulley</p>  <p>10pcs</p>	<p>34 Triceps rope pull</p> 	
<p>35 Handle</p>  <p>1pc</p>	<p>36 Ankle strap</p>  <p>1pc</p>	<p>37 Hook</p>  <p>2pcs</p>		

Assembly

STEP 1

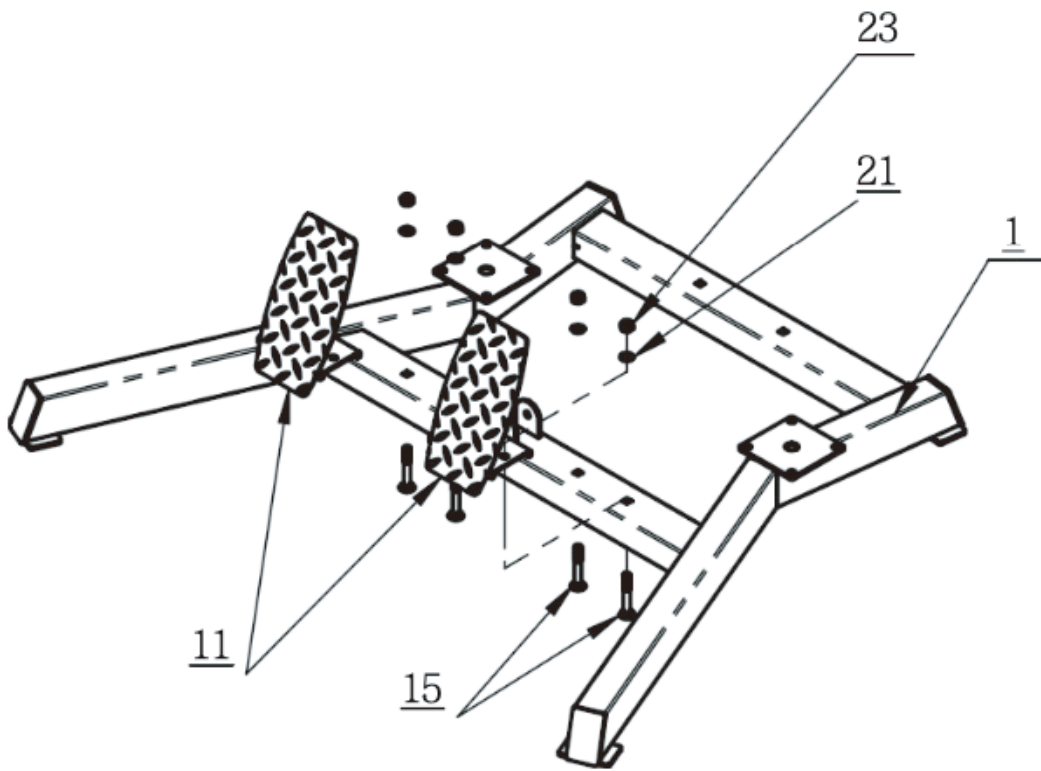

STEP 2

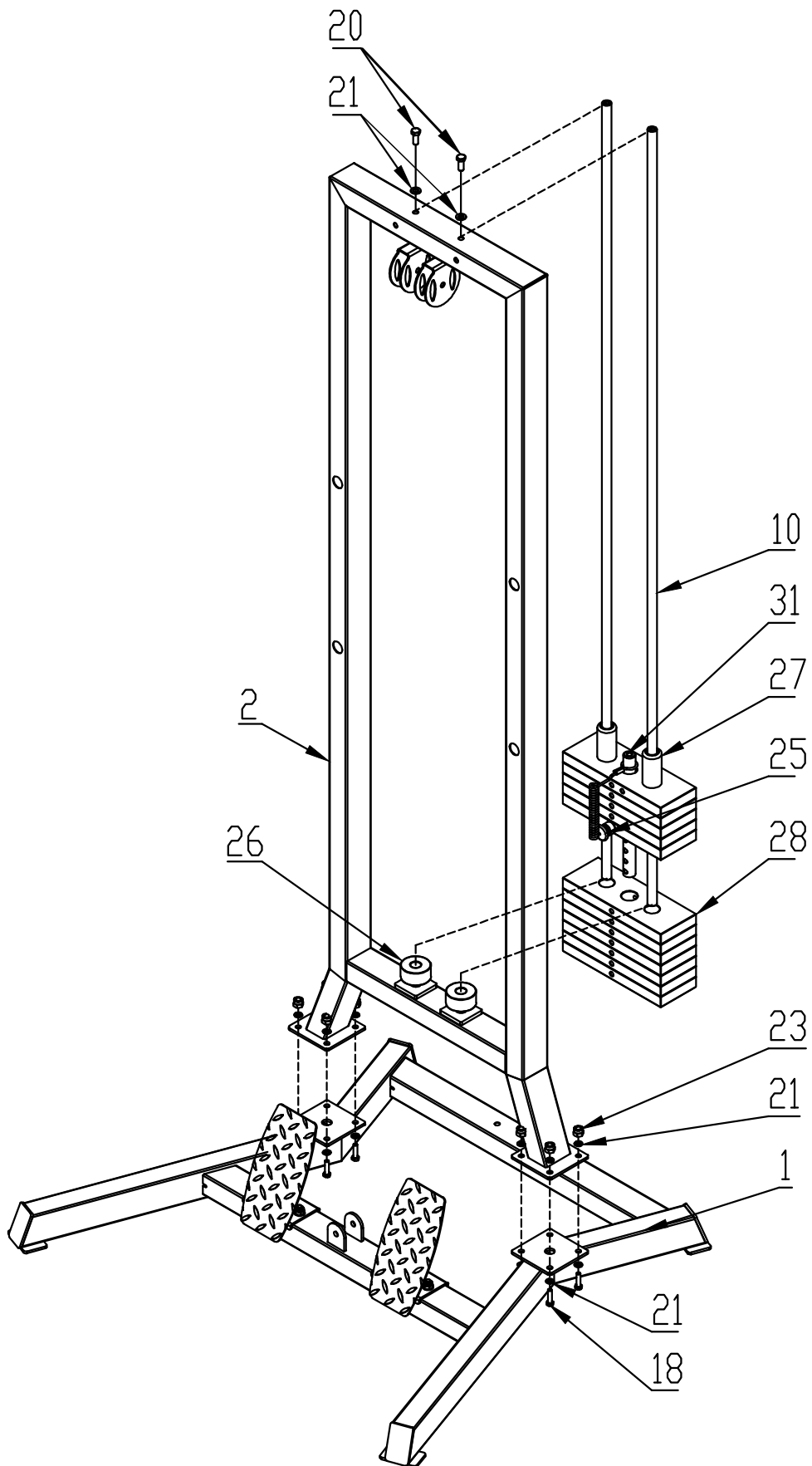

STEP 3

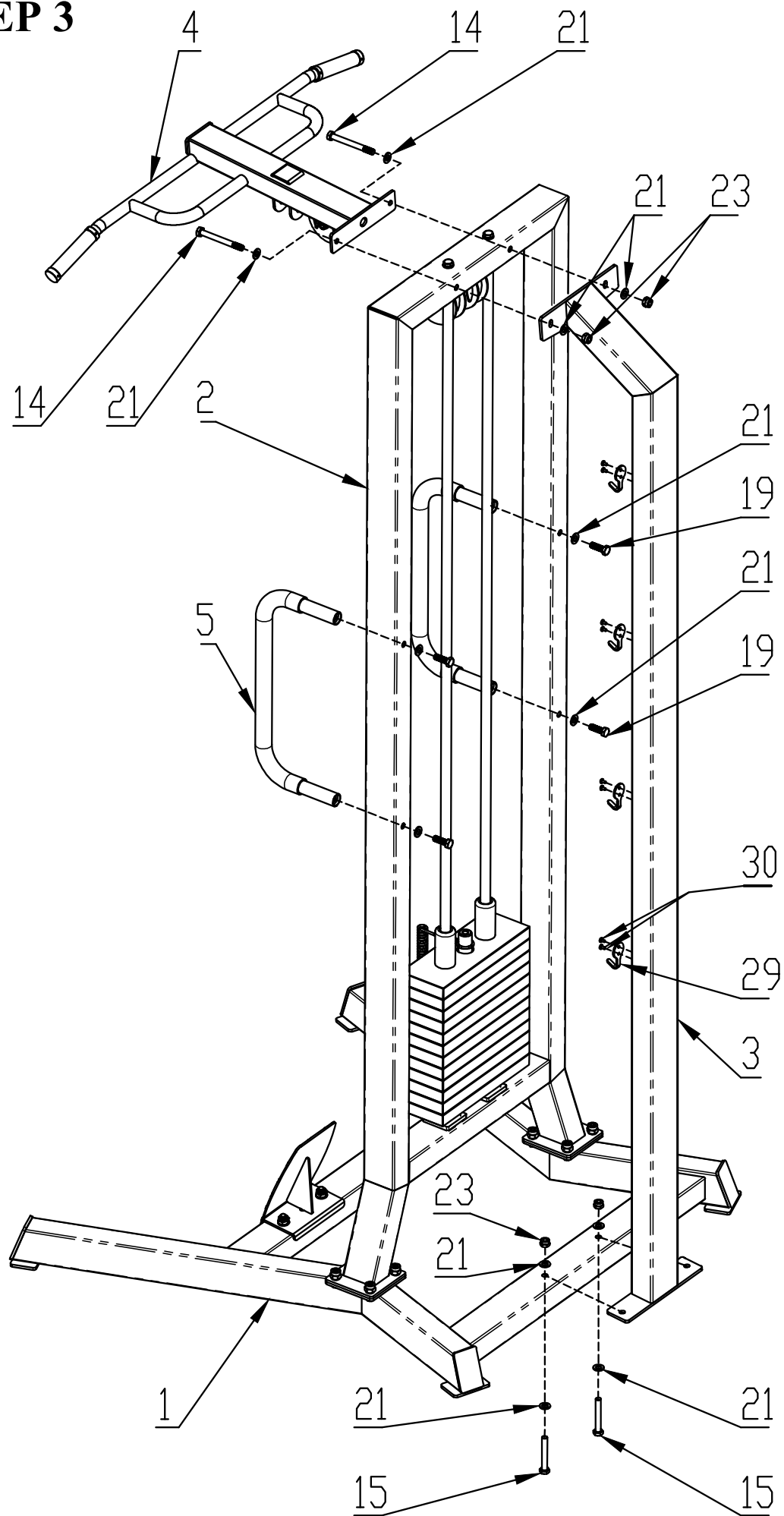

STEP 4

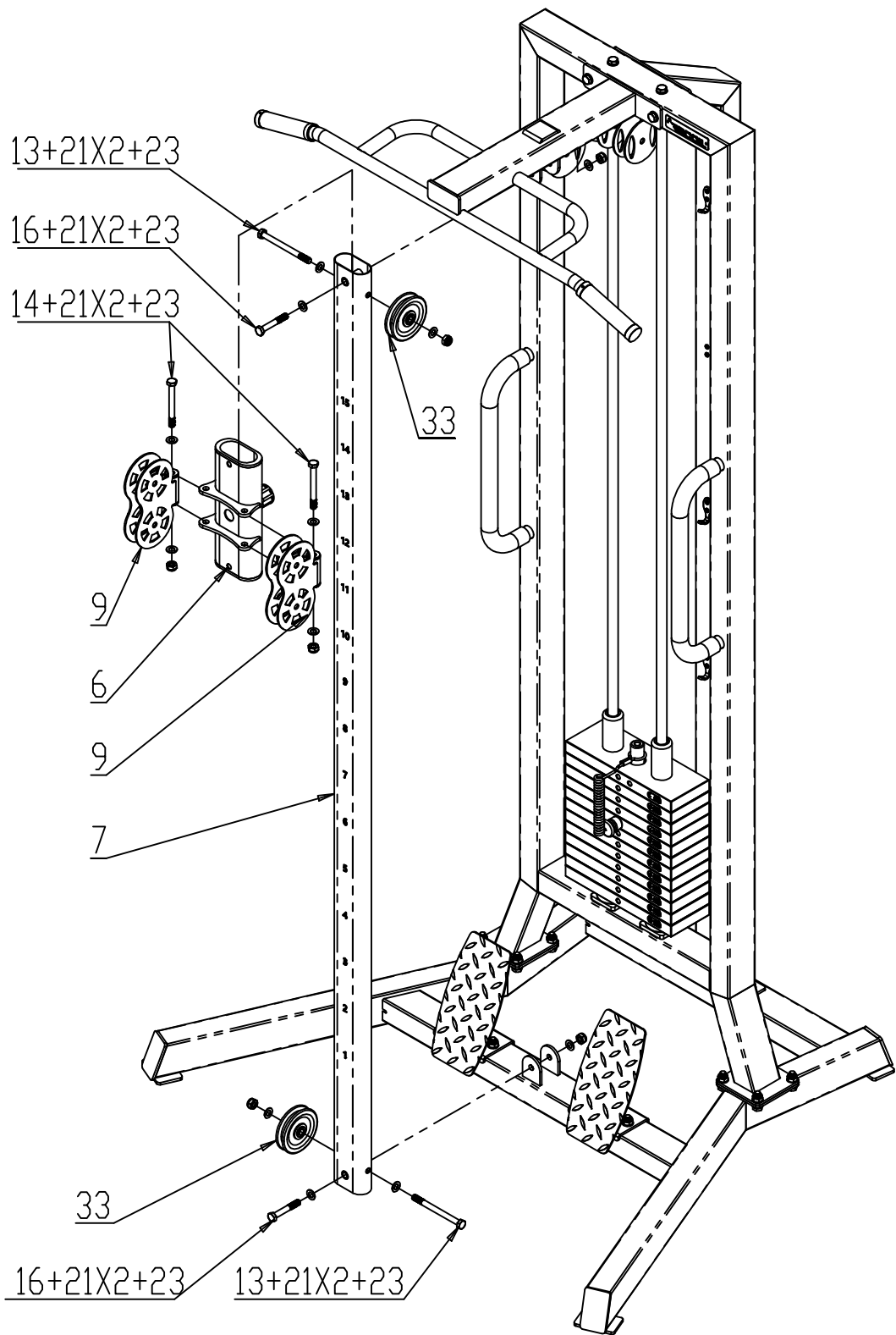

Install the upper and lower pulleys at last

STEP 5

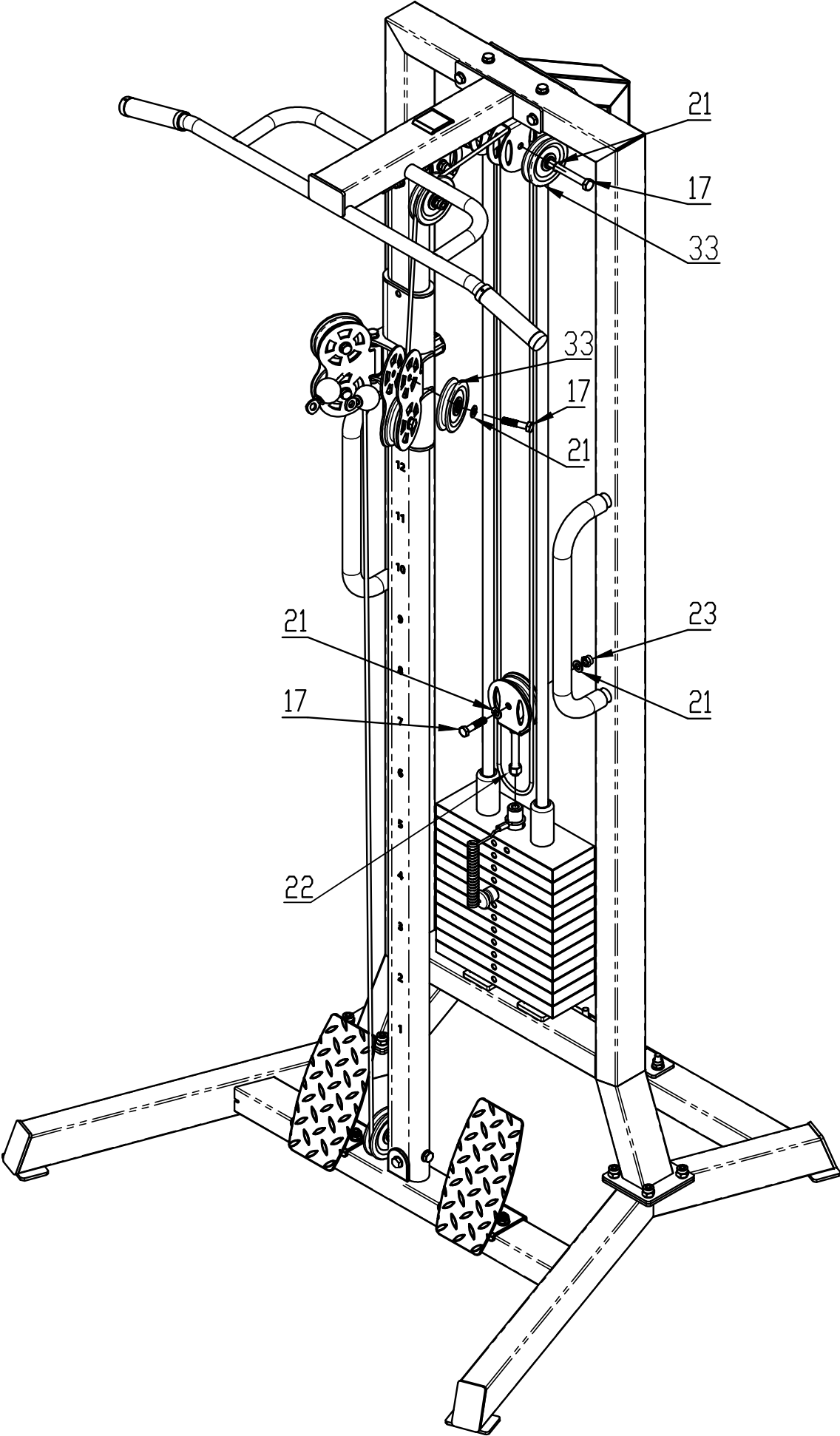

STEP 6

Cable assembly diagram

