

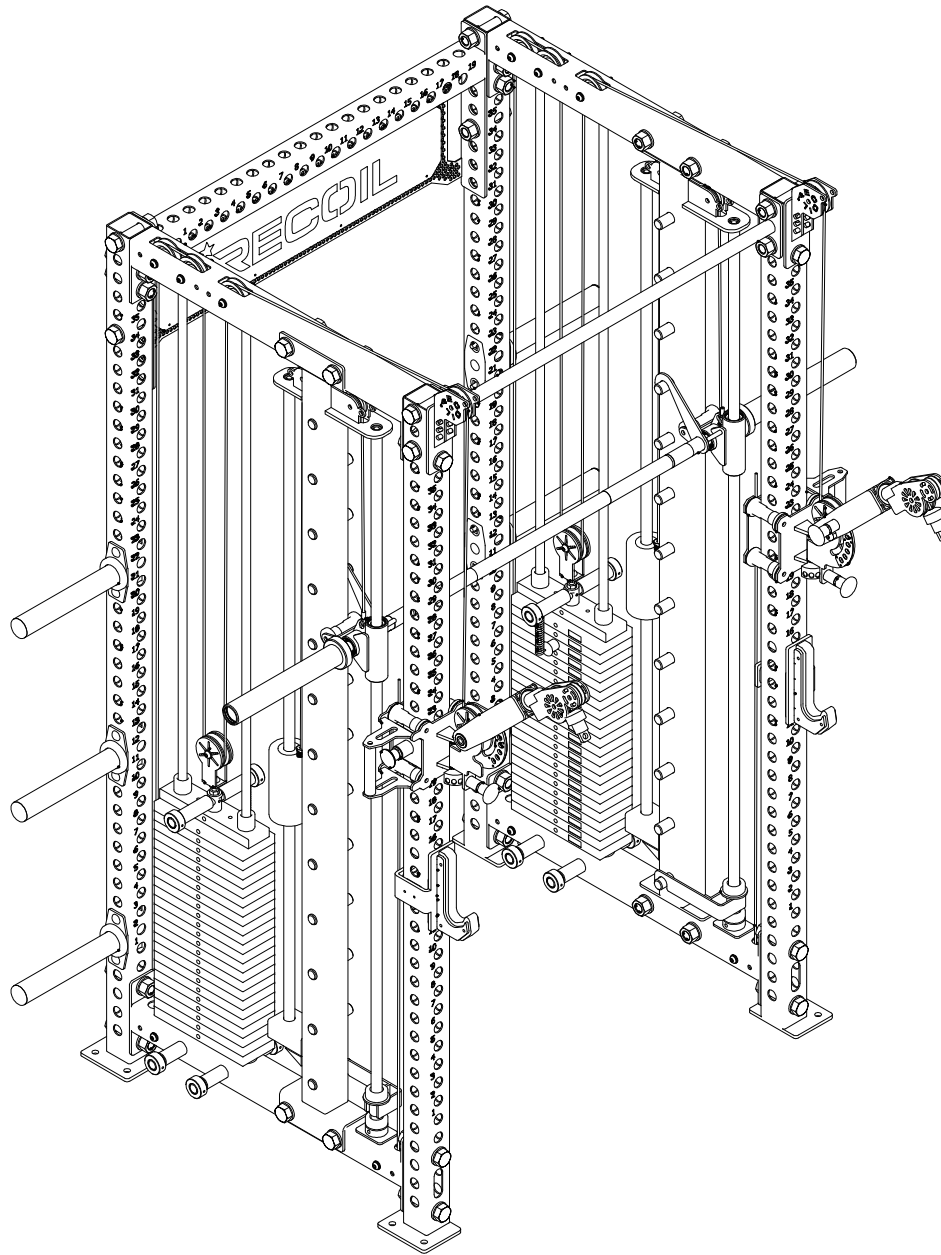

# Justerbart Multirack med Viktmagasin R82 REC1 RG7582A



## ASSEMBLY INSTRUCTIONS

### A-PEX Rack

Read all precautions and instructions in this manual before using this equipment

Assembly Caution	-----	3
Part List	-----	4
Hardware List	-----	4
Step 1	-----	5
Step 2	-----	6
Step 3	-----	7
Step 4	-----	8
Step 5	-----	9
Step 6	-----	10
Step 7	-----	11
Step 8	-----	12

# ASSEMBLY CAUTION

Please carefully read the following information before installation

**Assembling requires at least two people**  
**Do not tighten all screws before assembly is complete**  
**Ensure that all accessories are complete.**

## ***Shortcut: A Lot of People Doing That Way***

To enhance your installation process for both speed and convenience, consider removing all accessories from the box, carefully opening the packaging, and arranging everything neatly on the floor. This preparation can streamline your setup experience.

## ***The following tools might help you improve your installation experience***

- Adjustable wrenches

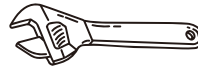

- Rubber hammers

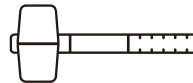

- Socket set

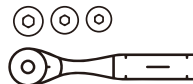

- Electric Wrench

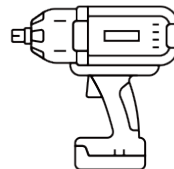

## **WARNING**



Choking hazard. Small parts-Please exercise caution if smallchildren or pets are present.









Sharp objects may be involved. Use precaution and protection.

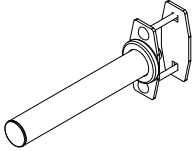
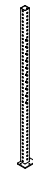
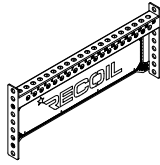
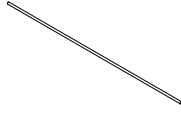
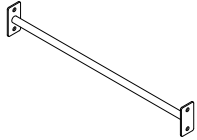
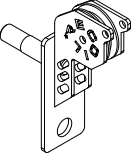

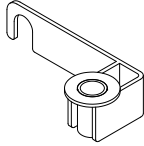
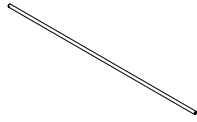
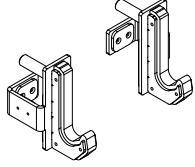
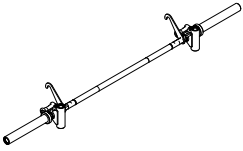
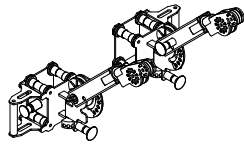
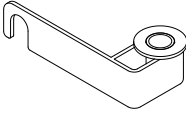

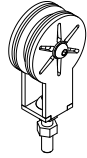
Heavy object. Use lifting aids and proper lifting techniques when moving

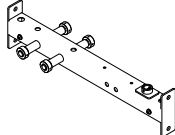
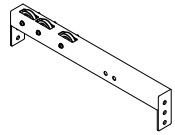
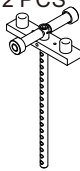
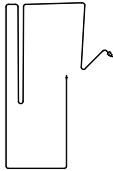
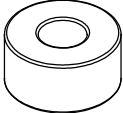
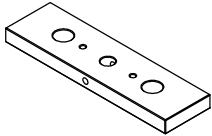
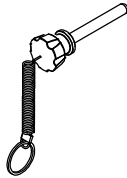
# PARTS LIST

<b>A1</b> Barbell plate hanging bar 6 PCS 	<b>A2</b> Station pole 2 PCS 	<b>A3</b> Trademark beam 1 PCS 	<b>A4</b> Sliding round steel I 4 PCS 	<b>A5</b> Single round pipe 1 PCS 
<b>A6</b> Top pulley frame 2 PCS 	<b>A7</b> Hanging rod support frame I 1 PCS 	<b>A8</b> Safety hook I 1 PCS 	<b>A9</b> Sliding round steel II 2 PCS 	<b>A10</b> J-Cup Hook 2 PCS 
<b>A11</b> Barbell bar 1 PCS 	<b>A12</b> Adjust the rocker arm 2 PCS 	<b>A13</b> Safety hook II 1 PCS 	<b>A14</b> Hanging rod support frame II 1 PCS 	<b>A15</b> Movable pulley frame 2 PCS 
<b>A16</b> Stainless steel station pole 2 PCS 	<b>A17</b> Lower connecting crossbeam 2 PCS 	<b>A18</b> Upper connecting crossbeam 2 PCS 	<b>B1</b> Top counterweight plate 2 PCS 	<b>B2</b> Steel wire rope 2 PCS 
<b>B3</b> Rubber pad 4 PCS 	<b>B4</b> Counterweight plate 46 PCS 	<b>B5</b> Limit pin 2 PCS 		

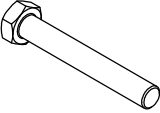
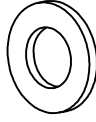
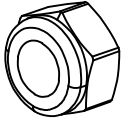
# HARDWARE LIST

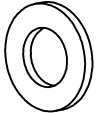
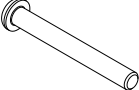
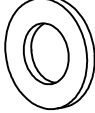
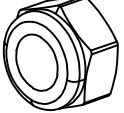
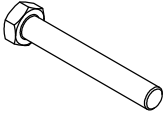
<b>1</b> Bolt M24*110 28 PCS 	<b>2</b> Washer φ24 62 PCS 	<b>3</b> Nut M32 32 PCS 	<b>4</b> Bolt M12*25 2 PCS 	<b>5</b> Washer φ12*35 2 PCS 
<b>6</b> Bolt M6*50 2 PCS 	<b>7</b> Washer φ6 4 PCS 	<b>8</b> Nut M6 2 PCS 	<b>9</b> Bolt M24*120 2 PCS 	

# STEP 1:

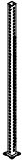
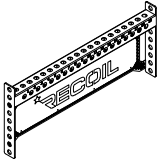
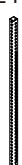
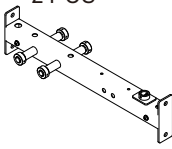
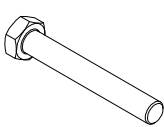
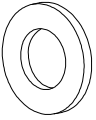
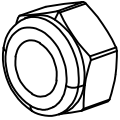
<b>A2</b> Station pole 2 PCS 	<b>A3</b> Trademark beam 1 PCS 	<b>A16</b> Stainless steel station pole 2 PCS 	<b>A17</b> Lower connecting crossbeam 2 PCS 	<b>2</b> Bolt M24*110 12 PCS 
<b>2</b> Washer $\phi 24$ 24 PCS 	<b>3</b> Nut M24 12 PCS 			

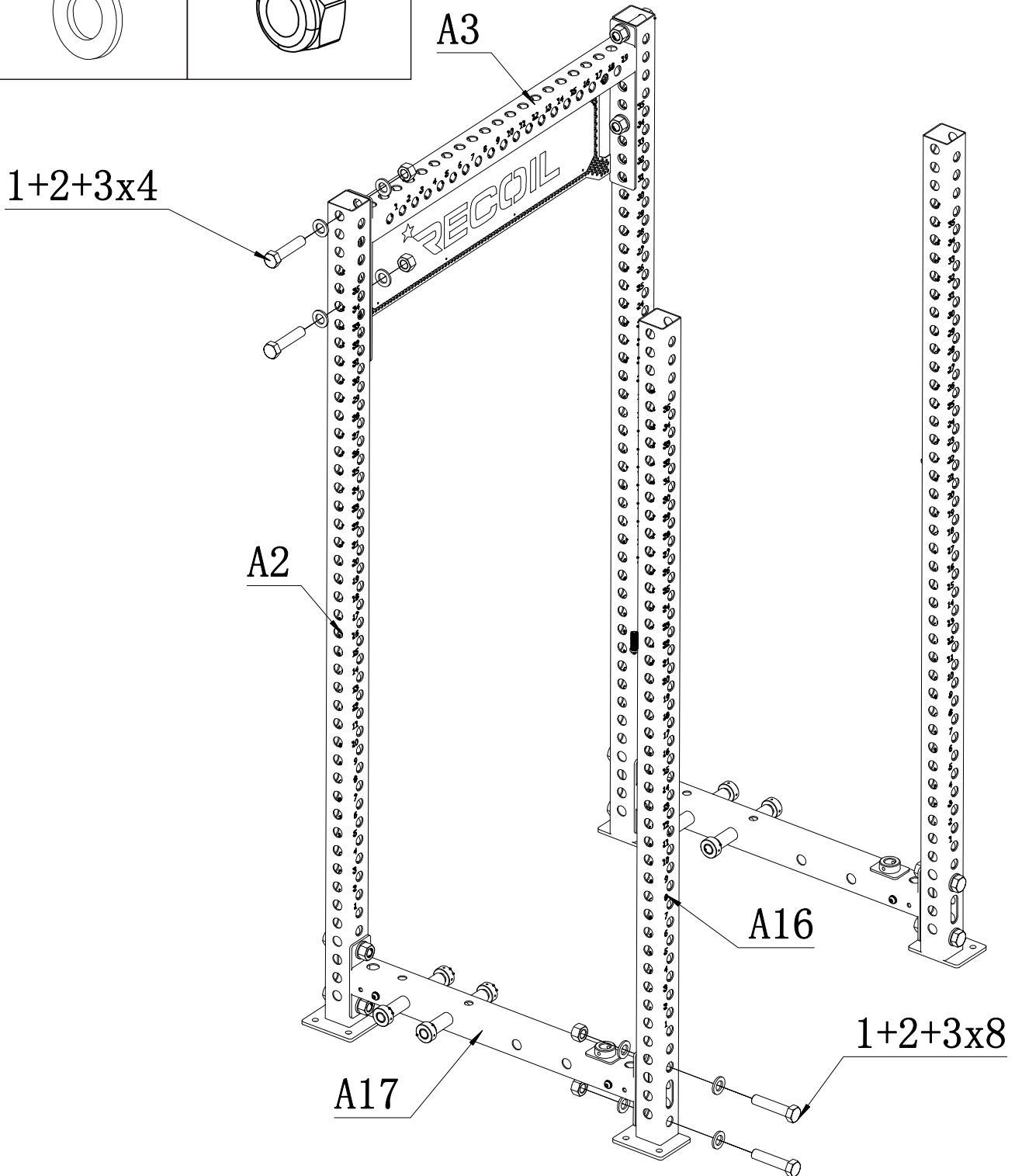

# STEP 2:

**A12** Adjust the rocker arm  
2 PCS

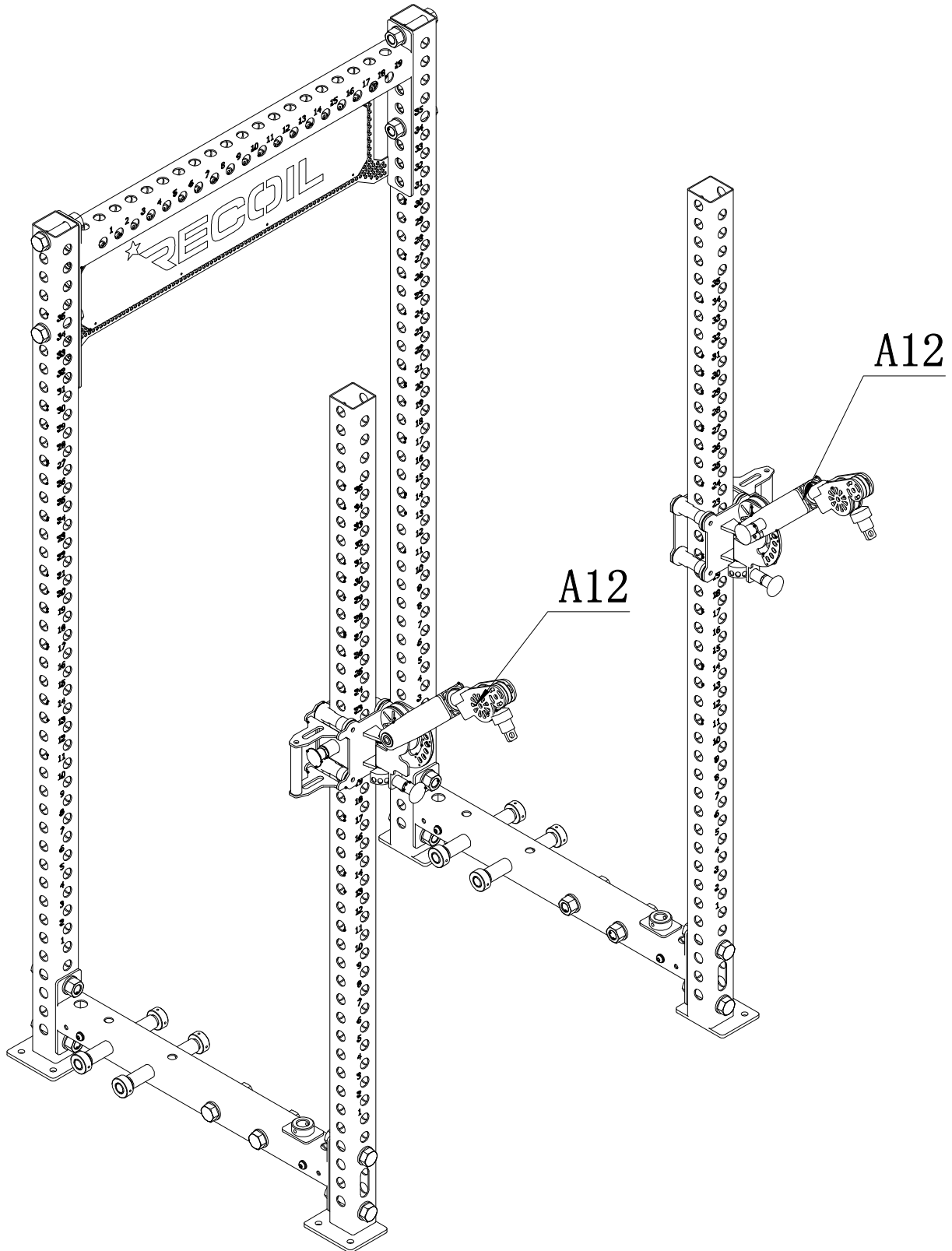
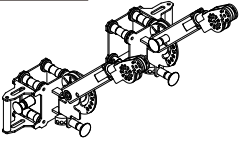

# STEP 3:

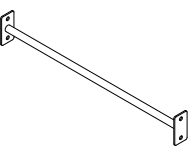
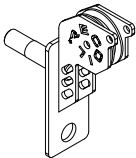
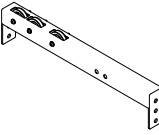
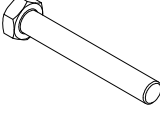
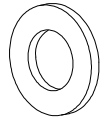
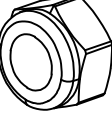
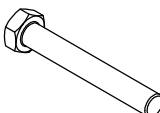
<b>A5</b> Single round pipe 1 PCS 	<b>A6</b> Top pulley frame 2 PCS 	<b>A18</b> Upper connecting crossbeam 2 PCS 	<b>1</b> Bolt M24*110 8 PCS 	<b>2</b> Washer φ24 22 PCS 
<b>3</b> Nut M24 12 PCS 	<b>9</b> Bolt M24*120 2 PCS 			

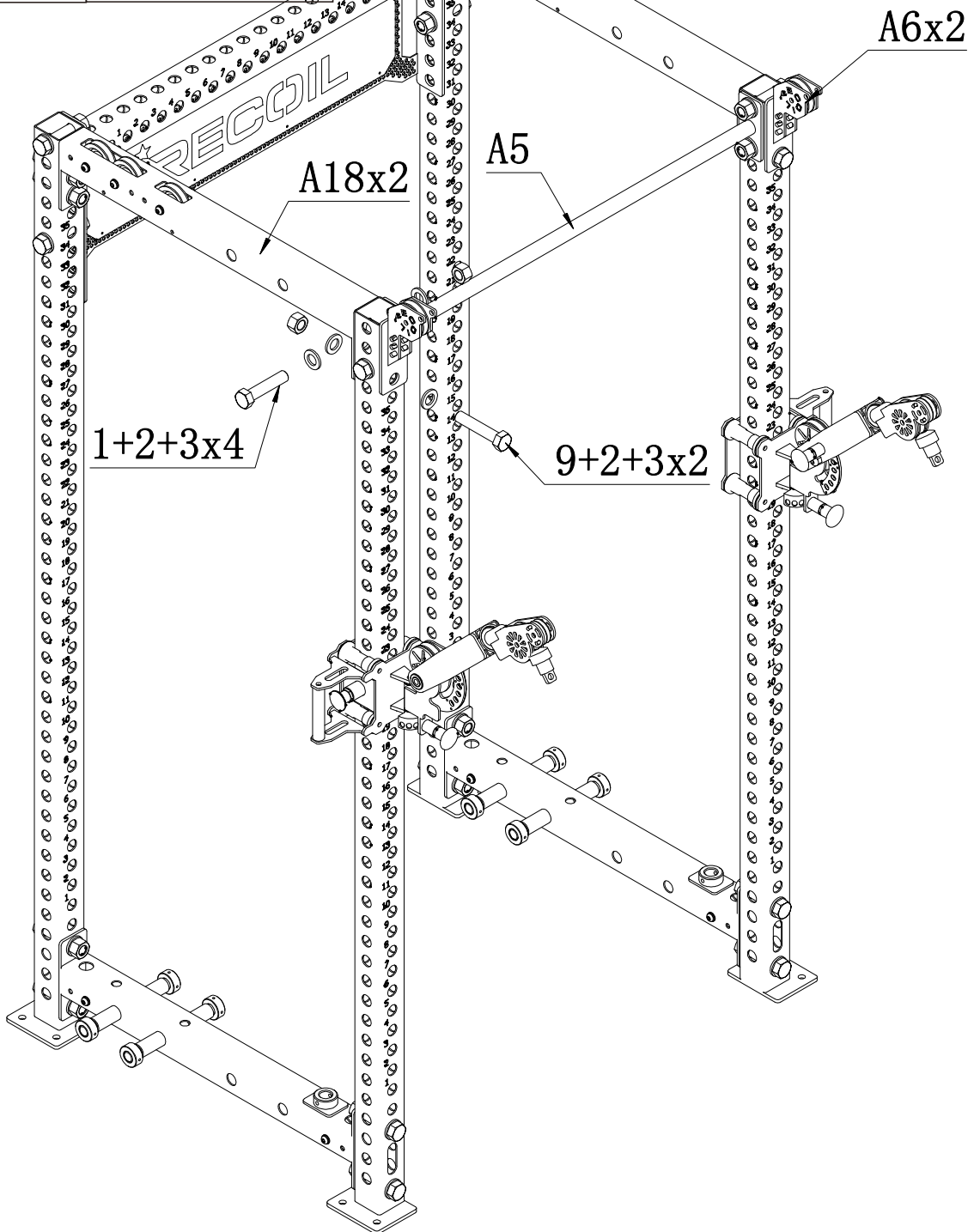

# STEP 4:

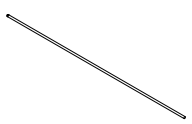
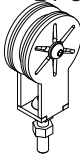
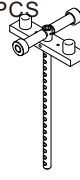
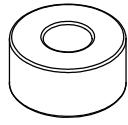
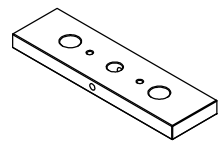

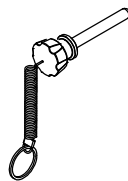
<b>A4</b> Supporting round steel 4 PCS 	<b>A15</b> Movable pulley frame 2 PCS 	<b>B1</b> Top counterweight plate 2 PCS 	<b>B3</b> Rubber pad 4 PCS 	<b>B4</b> Counterweight plate 46 PCS 
--	---	---	--	--

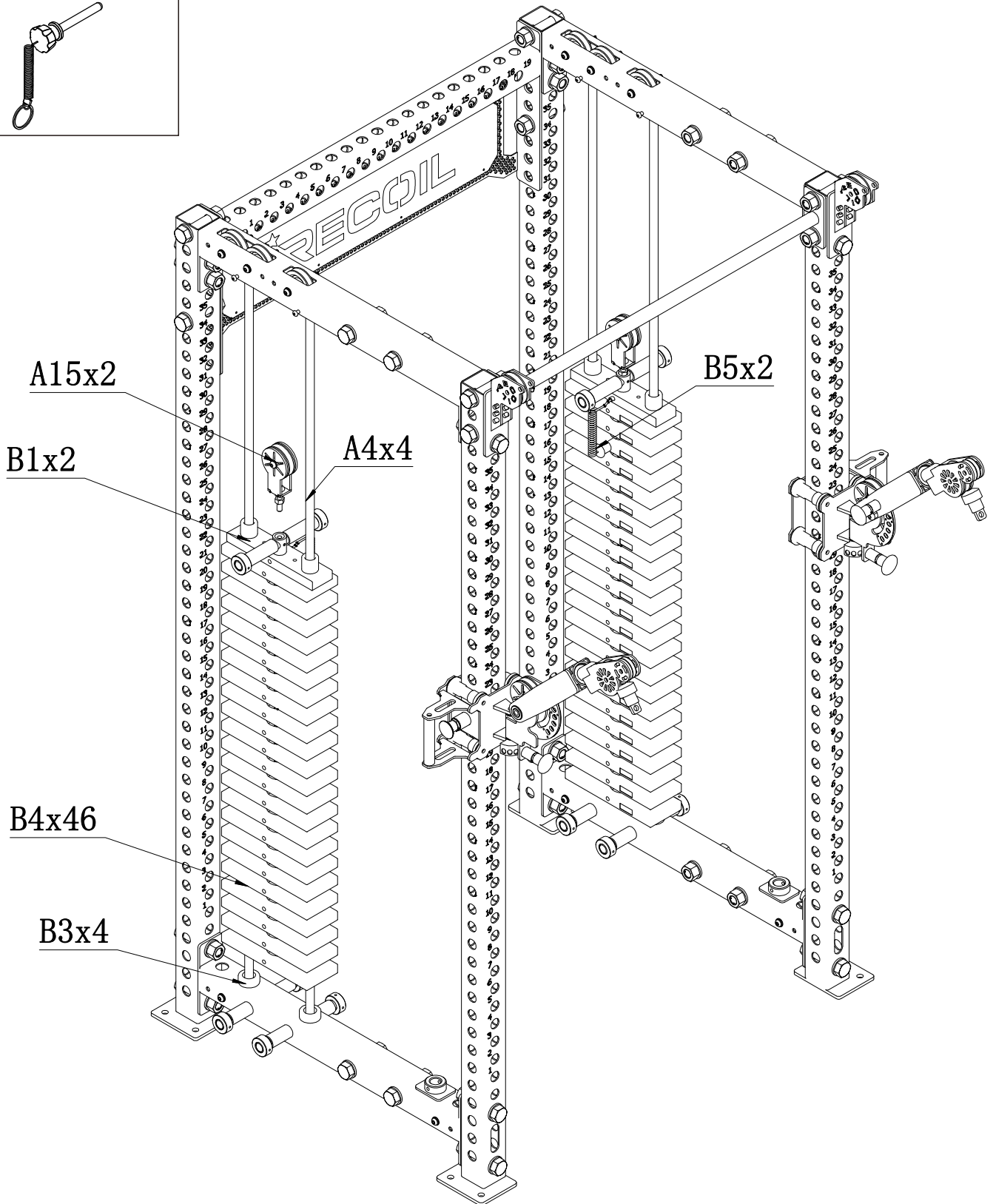
<b>B5</b> Limit pin 2 PCS 
---





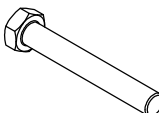
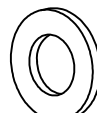
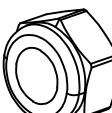

# STEP 6:

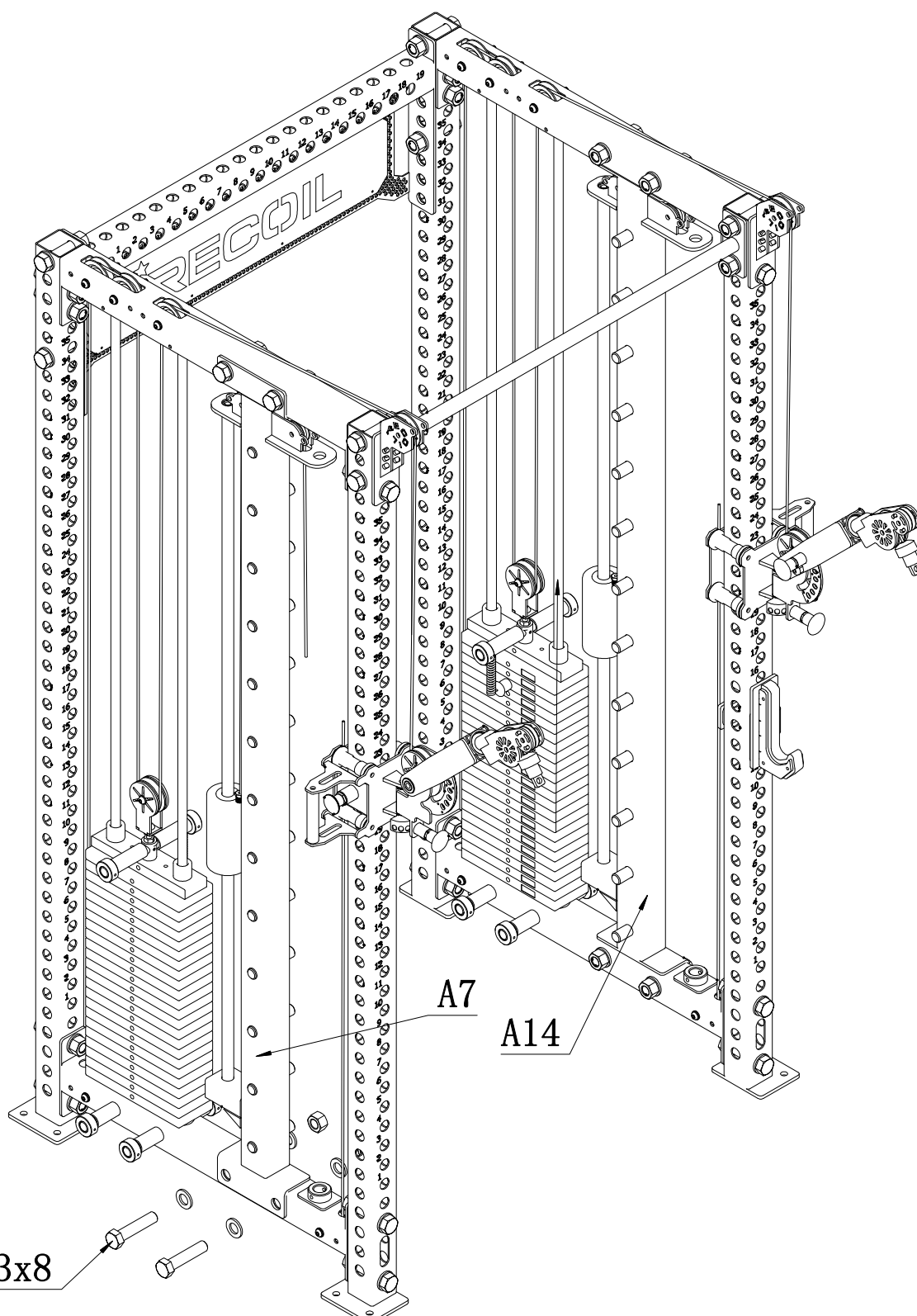
<b>A7</b> Hanging rod support frame I 1 PCS 	<b>A14</b> Hanging rod support frame II 1 PCS 	<b>1</b> Bolt M24*110 8 PCS 	<b>2</b> Washer $\phi 24$ 16 PCS 	<b>3</b> Nut M24 8 PCS 
---	---	---	--	--

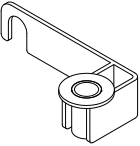
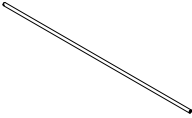
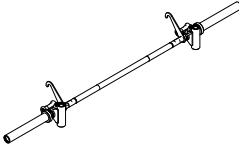
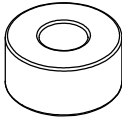
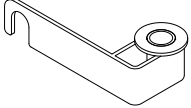

# STEP 7:

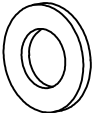
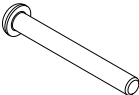
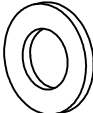
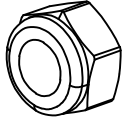
<b>A8</b> Safety hook I 1 PCS 	<b>A9</b> Sliding round steel II 2 PCS 	<b>A11</b> Barbell bar 1 PCS 	<b>B3</b> Rubber pad 4 PCS 	<b>A13</b> Safety hook II 1 PCS 
<b>4</b> Bolt M12*25 2 PCS 	<b>5</b> Washer φ12*35 2 PCS 	<b>6</b> Bolt M6*60 2 PCS 	<b>7</b> Washer φ6 4 PCS 	<b>8</b> Nut M6 2 PCS 

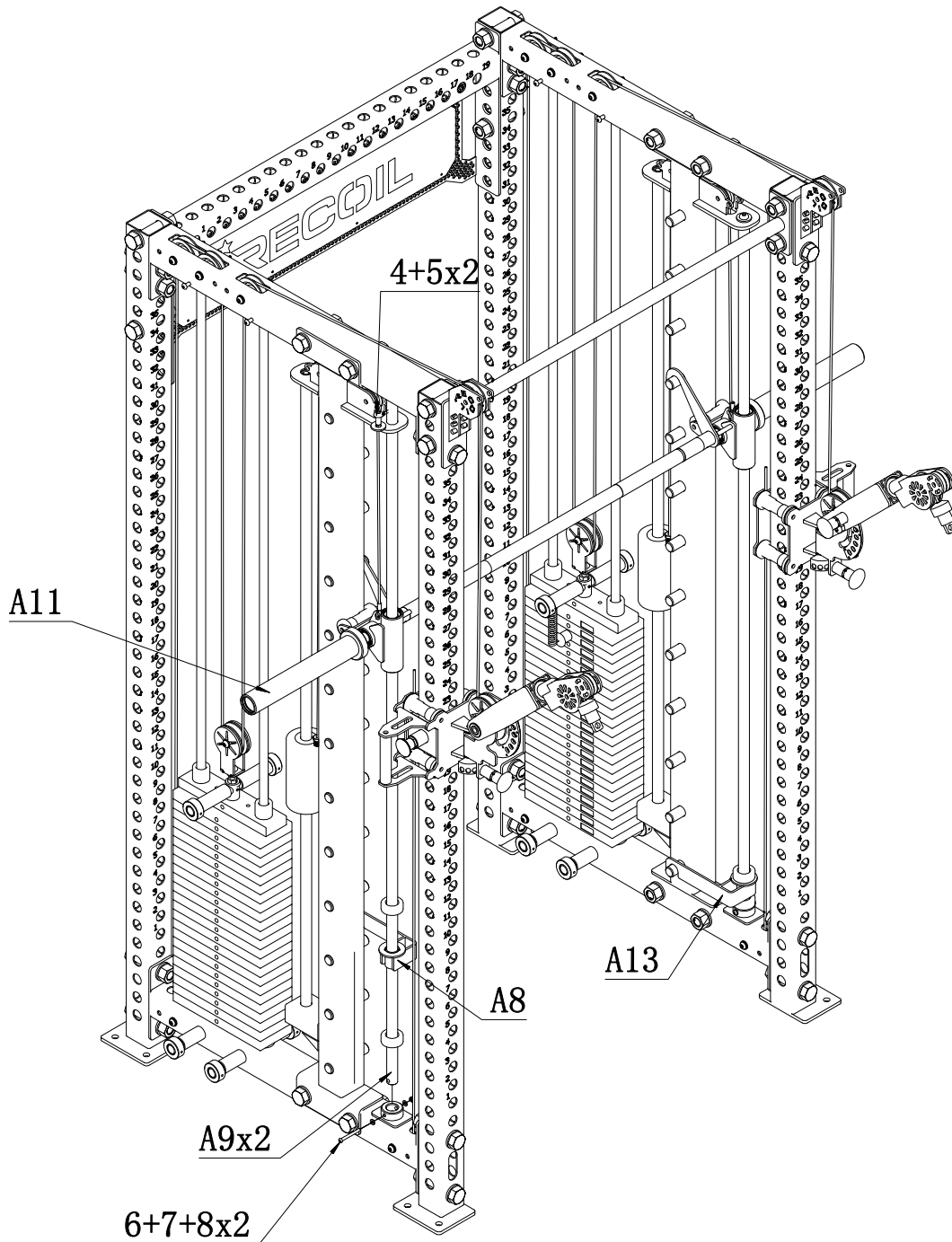

# STEP 8:

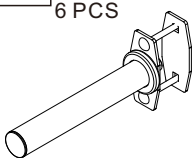
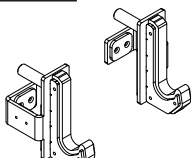
<b>A1</b> Barbell plate hanging bar 6 PCS 	<b>A10</b> J-Cup Hook 2 PCS 
---	---

