

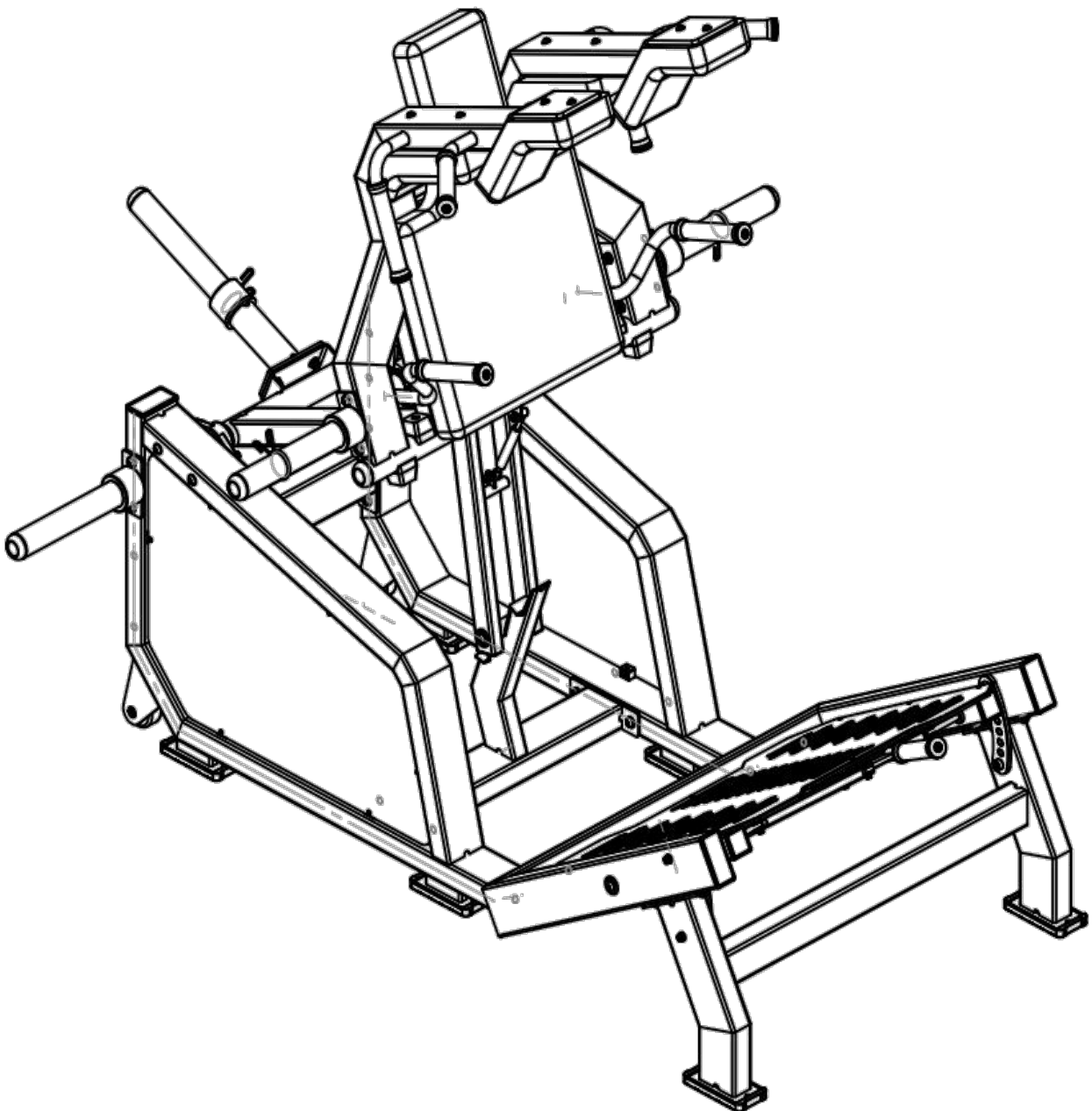





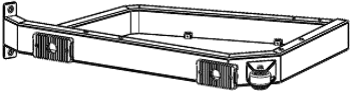

# ★ RECOIL

## REC1 F0027

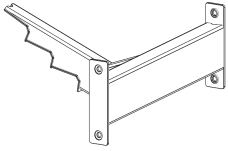
### Assembly Instructions

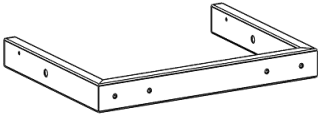
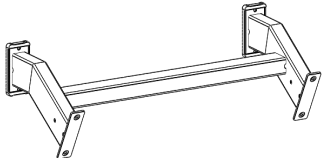
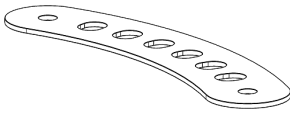
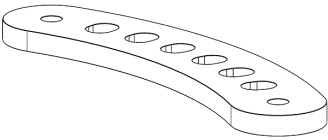

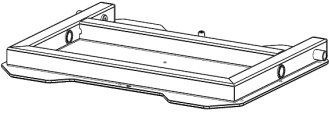
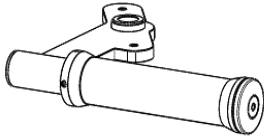
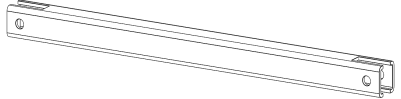
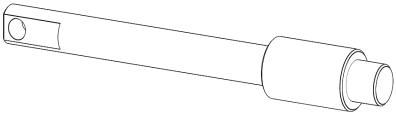
# Accessories list (separate packaging)

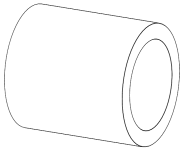
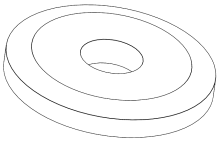
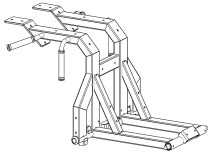
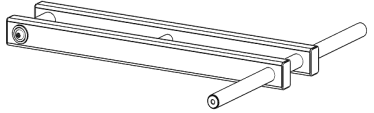
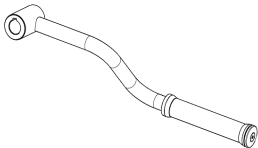
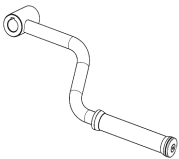
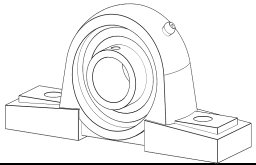
					
No.1	5066-01S Left base assembly*1pc	No.2	5066-02S Base right component*1pc	No.3	5066-07 limit welding set*1pc
					
No.4	5066-06 Connection support welding set*1pc	No.5	5066-03S Fixed footrest assembly*1pc	No.6	5066-04S Support pedal assembly*1pc
					
No.7	5066-0006 Stainless steel adjustment plate*2pcs	No.8	5066-0005 Adjustment plate*2pcs	No.9	Q1010-5016 Limit sleeve column*4pcs
					
No.10	5066-05S Pedal assembly*1pc	No.11	5066-13S Adjustment handle assembly*1pc	No.12	5066-0018 Connecting pipe*2pcs
					
No.13	5066-0014 Latch (galvanized) *2pcs	No.14	5066-0003 Galvanized shaft*1pc	No.15	5066-0004 Nylon sleeve*2pcs
					
No.16	5013-0211 Gasket*4pcs	No.17	5066-08S Boom assembly*1pc	No.18	5066-09S Support assembly*1pc
					
No.19	5066-10S Left handle assembly*1pc	No.20	5066-11S Right handle assembly*1pc	No.21	UCP205 bearing seat*1pc

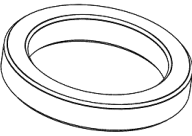
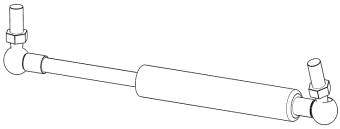
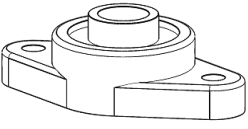
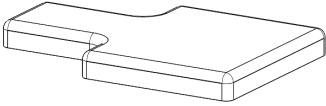
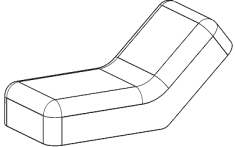
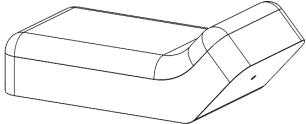
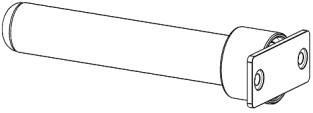
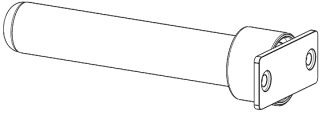
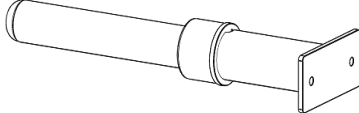
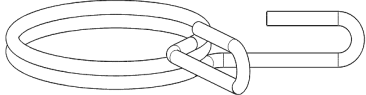
					
No.22	GT004 spacer*2pcs	No.23	08YQ-18-8-220-100N gas spring*1pc	No.24	UCFL205 bearing seat*2pcs
					
No.25	5066-0009 Large backrest*1pc	No.26	5066-0007 Bend shoulder pad *2pcs	No.27	5066-0008 Shoulder pad*2pcs
					
No.28	5065-0900 Barbell Plate Set*2pcs	No.29	04-8101-1200 Barbell Plate Set*2pcs	No.30	5066-12S barrel assembly*1pc
					
No.31	Butterfly clip*3pcs	No.32		No.33	

# Blister Pack Screw List

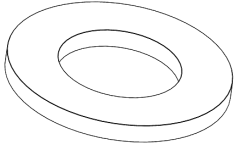
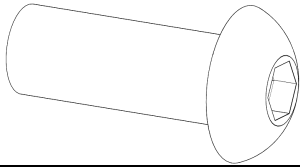
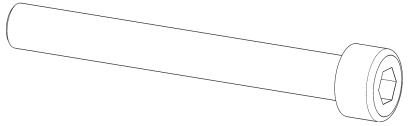
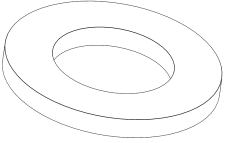
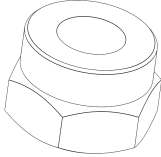
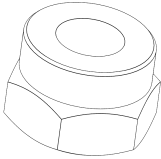
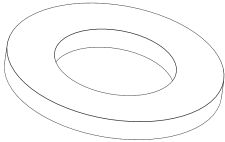
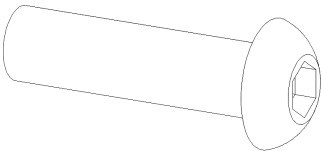
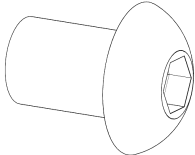
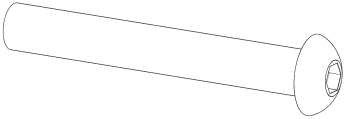
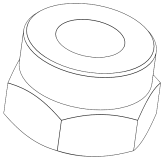
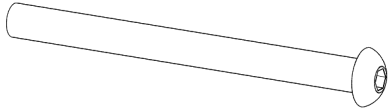
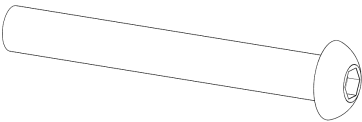
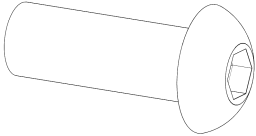
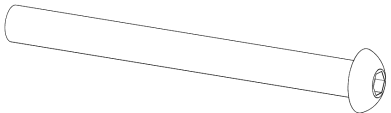
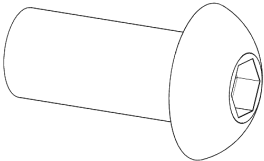
					
A	Flat washer (galvanized) Φ10*49pcs	B	Flat head screw M10X30*20pcs	C	Hexagon socket head screw (half-thread galvanized) M8X75*4pcs
					
D	Flat washer (galvanized) Φ8*24pcs	E	Lock nut (galvanized) M8*6pcs	F	Lock nut (galvanized) M6*4pcs
					
G	Flat washer (galvanized) Φ6*8pcs	H	Hexagon socket head screw (galvanized) M6X25*4pcs	J	Hexagon socket head screw (galvanized) M10X16*5pcs
					
K	Hexagon socket head screw (half-thread galvanized) M10X80*4pcs	L	Lock nut (galvanized) M10*14pcs	M	Hexagon socket head screw (half-thread galvanized) M10X130*4pcs
					
N	Hexagon socket head screw (half-thread galvanized) M8X70*10pcs	O	Hexagon socket head screw (galvanized) M8X25*8pcs	P	Hexagon socket head screw (half-thread galvanized) M10X120*4pcs
					
Q	Hexagon socket head screw (galvanized) M10X25*2pcs				

# Assembly steps

Step	Item NO	Name	Qty
1	1	5066-01S Left base assembly	1
	2	5066-02S Base right assembly	1
	3	5066-07 Limit welding group	1
	4	5066-06 Connection support welding group	1
	A	Flat washer (galvanized) $\Phi 10$	8
	B	Flat head screw M10X30	8

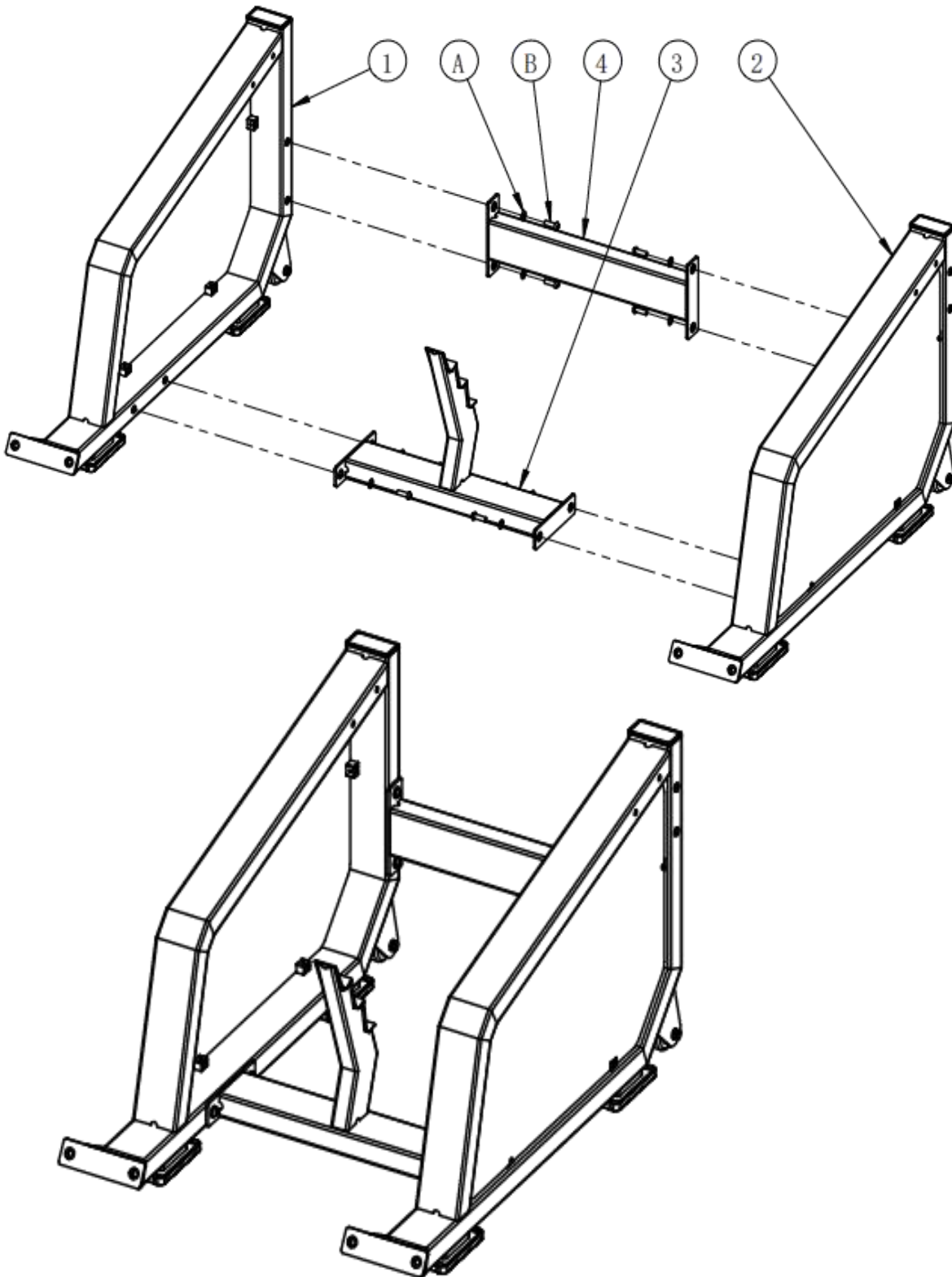

# Assembly steps

Step	Item NO	Name	Qty
2	5	5066-03S Fixed footrest assembly	1
	6	5066-04S Support footrest assembly	1
	B	Flat head screw M10X30	4
	A	Flat washer (galvanized) $\Phi$ 10	4

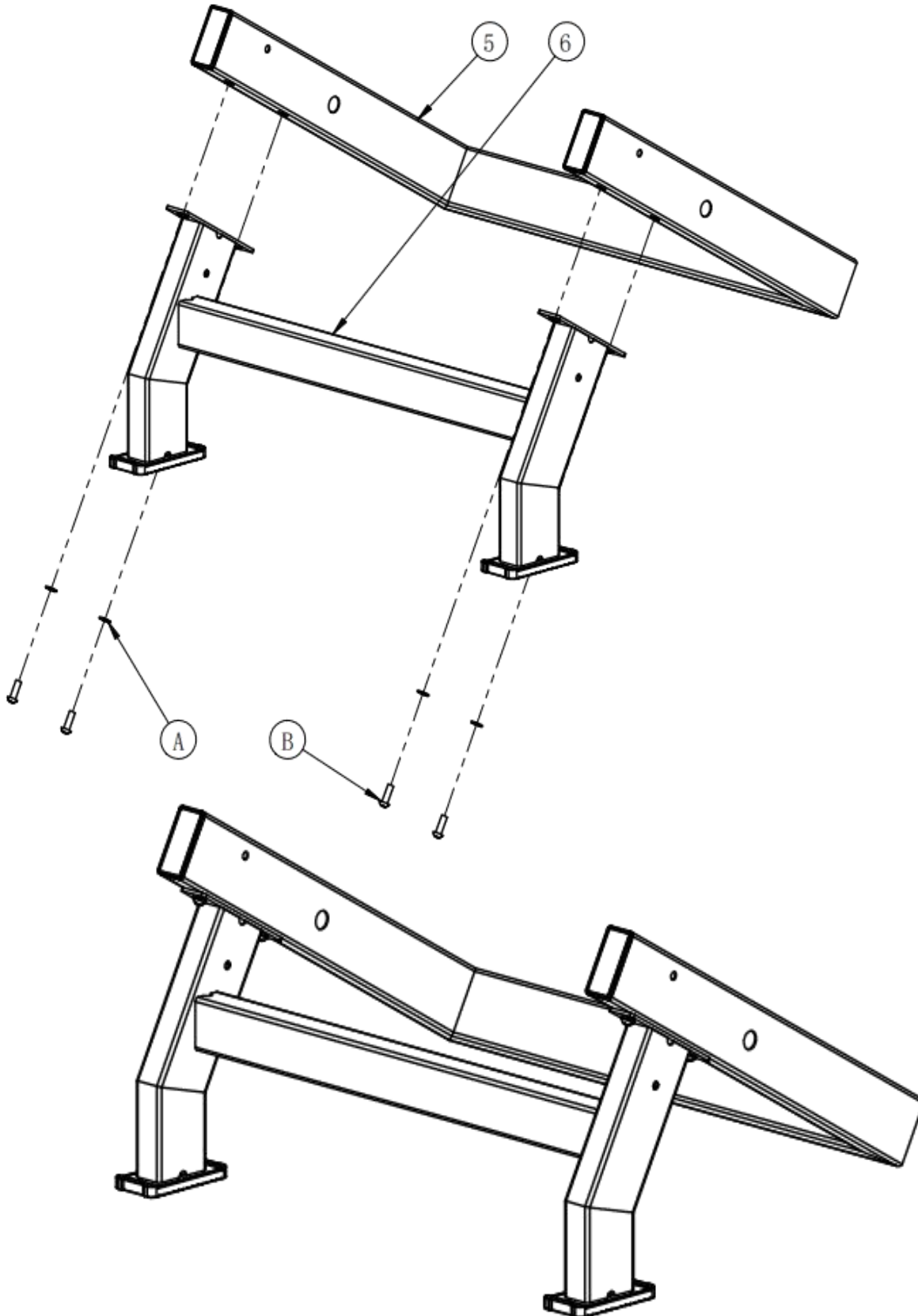

# Assembly steps

Step	Item NO	Name	Qty
3	B	Flat head screw M10X30	4
	A	Flat washer (galvanized) $\Phi$ 10	4

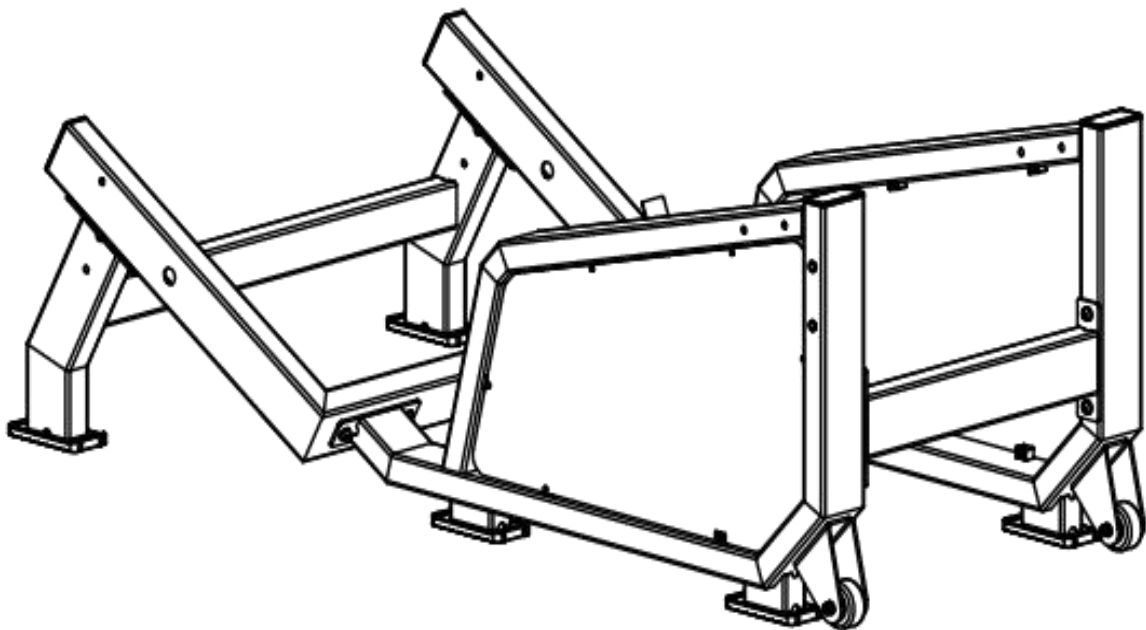
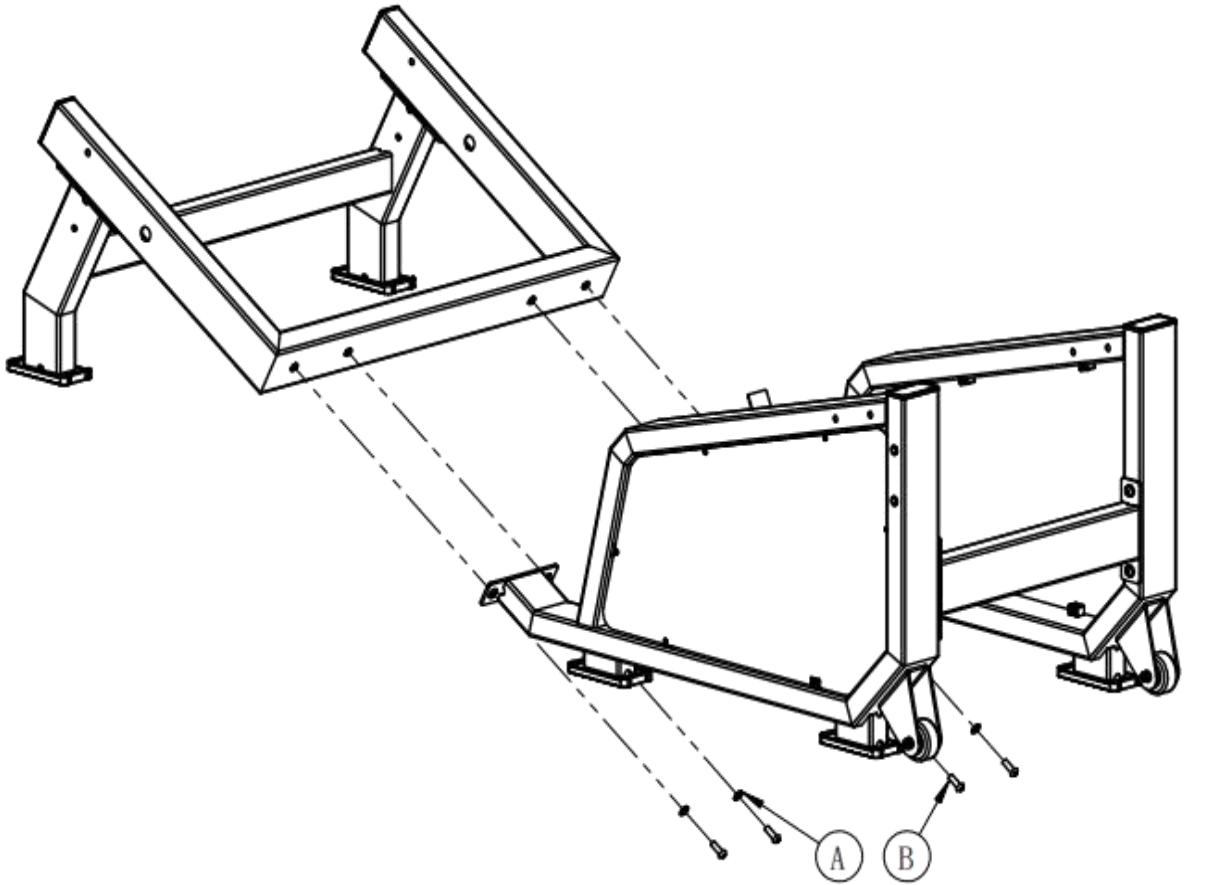

# Assembly steps

Step	Item NO	Name	Qty
4	7	5066-0006 Stainless steel adjustment plate	2
	8	5066-0005 Adjustment plate	2
	9	Q1010-5016 Limit sleeve	4
	C	Hexagon socket head screw (half-thread galvanized) M8X75	4
	D	Flat washer (galvanized) $\Phi 8$	4
	E	Lock nut (galvanized) M8	4

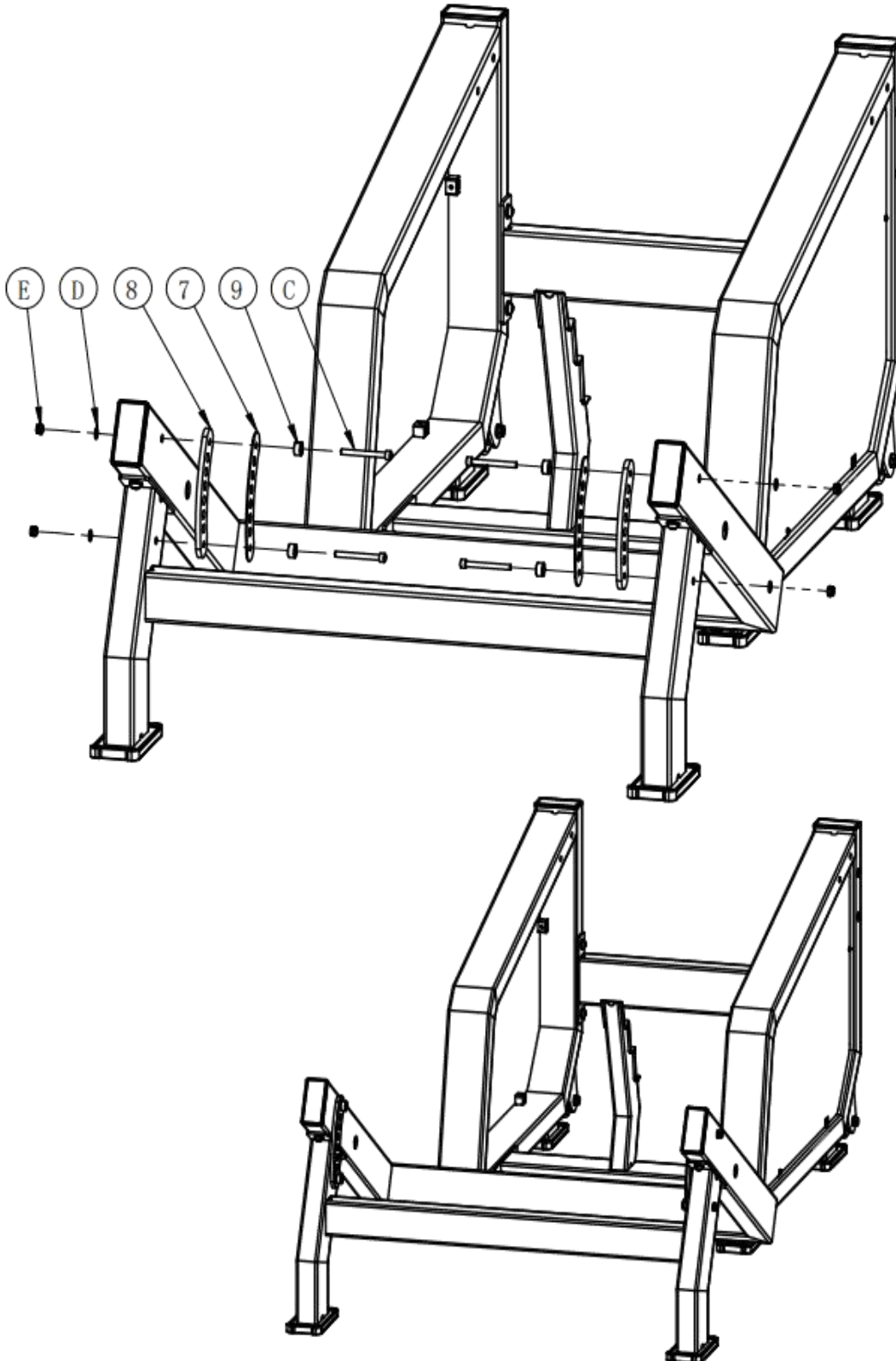



# Assembly steps

Step	Item NO	Name	Qty
5	10	5066-05S Foot pedal assembly	1
	11	5066-13S Adjustment handle assembly	1
	12	5066-0018 Connecting pipe	2
	13	5066-0014 Latch (galvanized)	2
	F	Lock nut (galvanized) M6	4
	G	Flat washer (galvanized) $\Phi 6$	8
	H	Hexagon socket head screw (galvanized) M6X25	4
	A	Flat washer (galvanized) $\Phi 10$	1
	J	Hexagon socket head screw (galvanized) M10X16	1

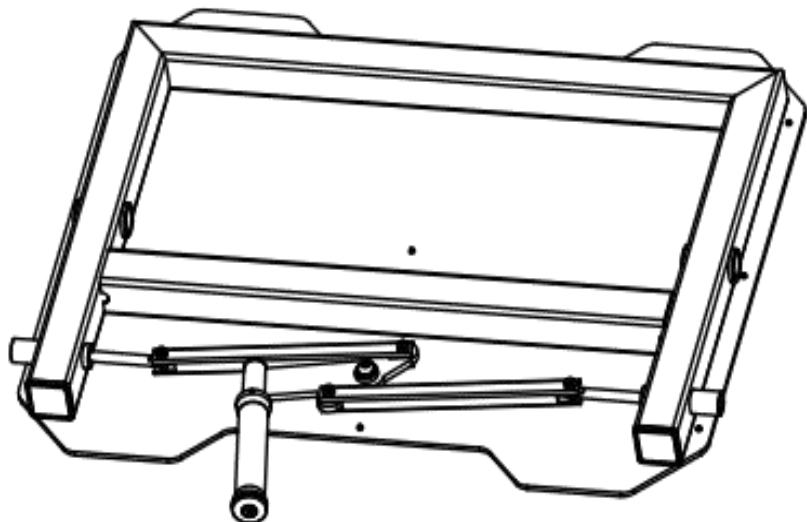
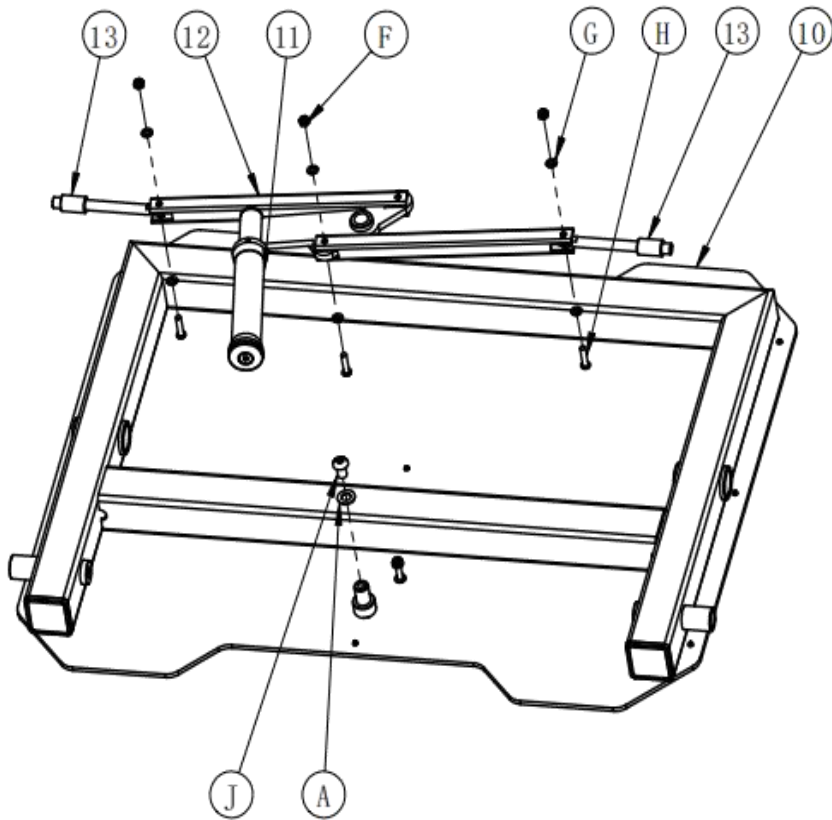

# Assembly steps

Step	Item NO	Name	Qty
6	14	5066-0003 Galvanized shaft	1
	15	5066-0004 Nylon sleeve	2
	16	5013-0211 Gasket	2
	J	Hexagon socket head screw (galvanized) M10X16	2

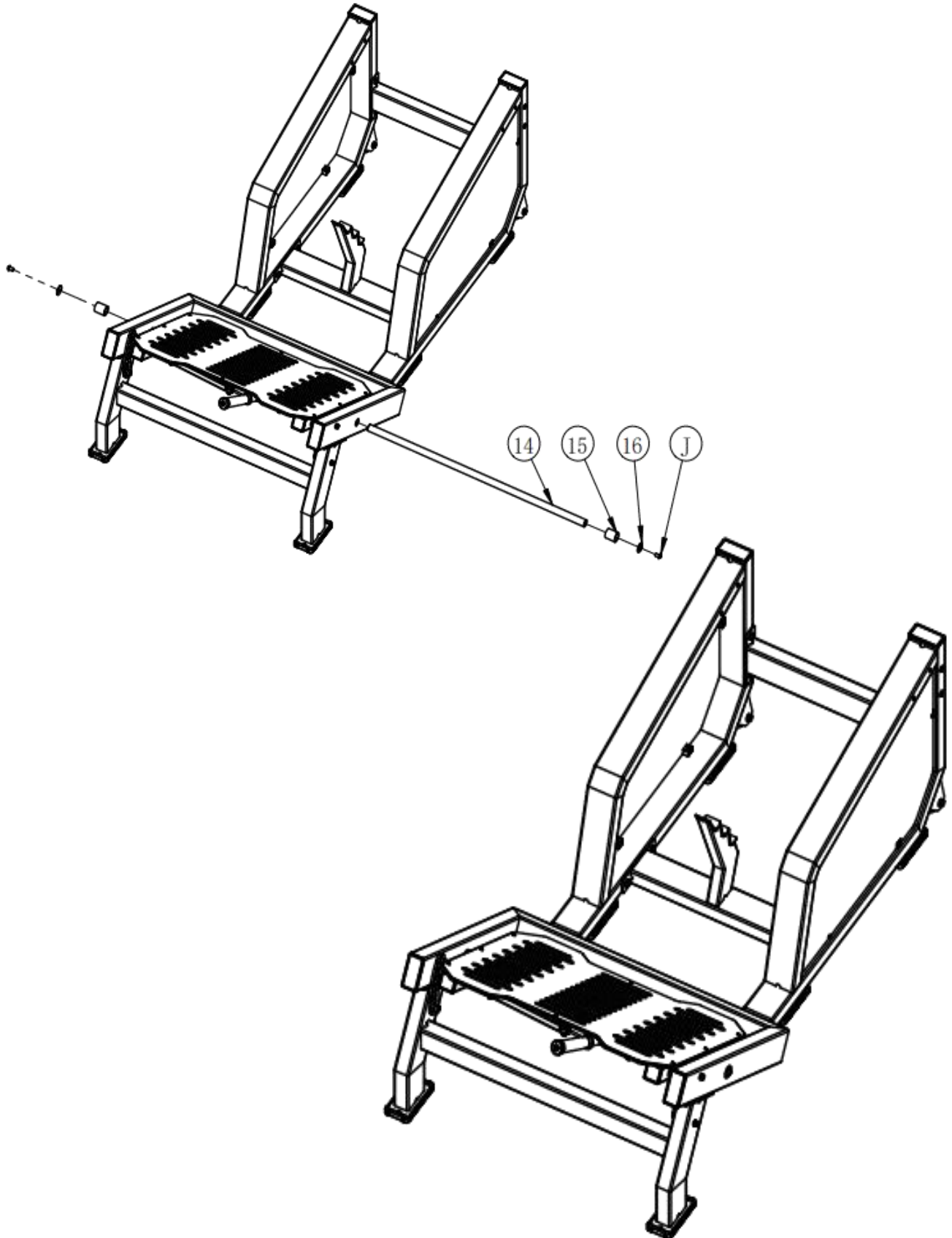

# Assembly steps

Step	Item NO	Name	Qty
7	17	5066-08S Boom Assembly	1
	18	5066-09S Support assembly	1
	19	5066-10S Left handle assembly	1
	20	5066-11S Right handle assembly	1
	21	UCP205 Bearing Unit	2
	16	5013-0211 Gasket	2
	J	Hexagon socket head screw (galvanized) M10X16	2
	22	GT004 Spacer	2
	K	Hexagon socket head screw (half-thread galvanized) M10X80	4
	A	Flat washer (galvanized) Φ10	8
	L	Lock nut (galvanized) M10	4

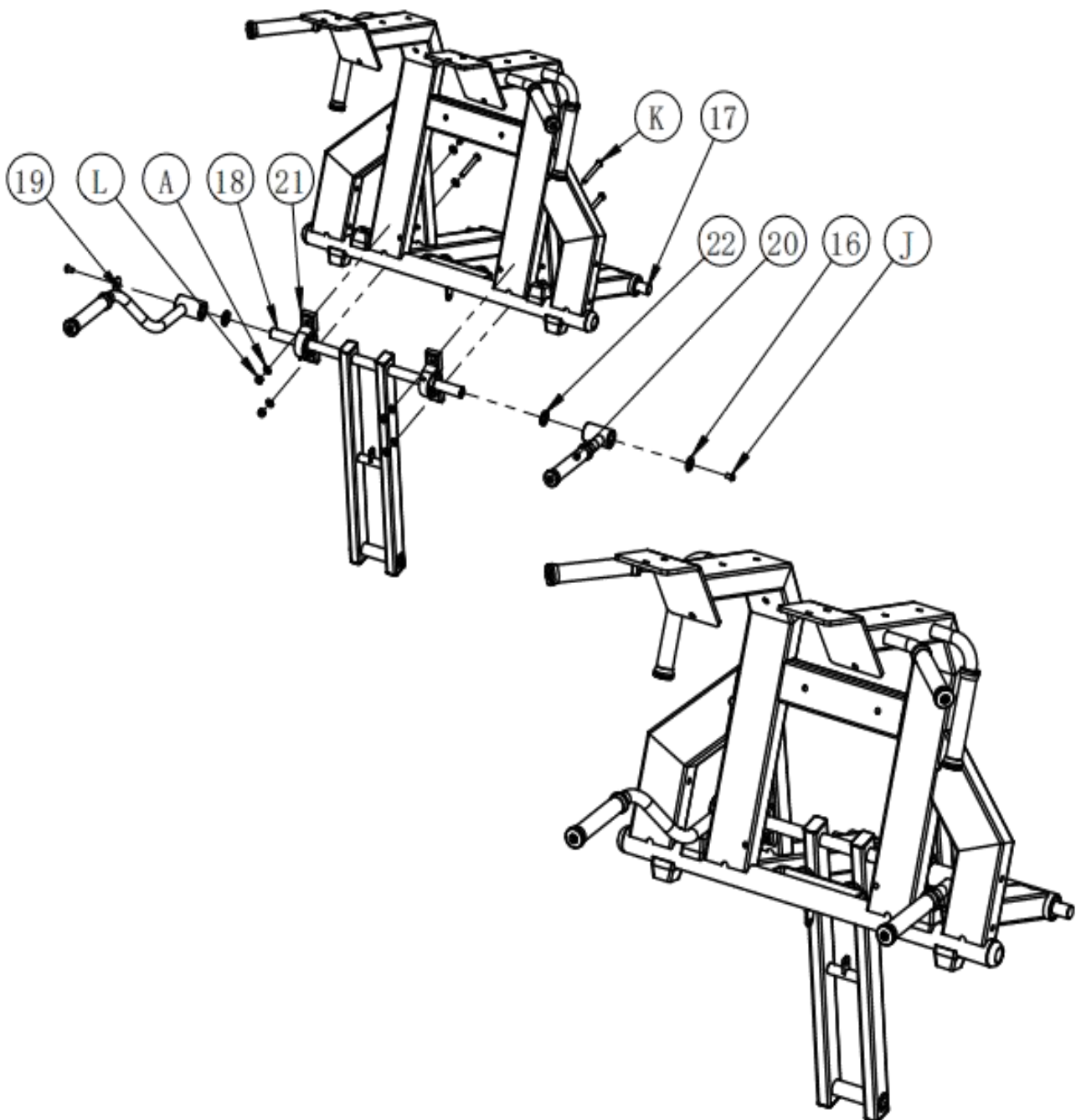

# Assembly steps

Step	Item NO	Name	Qty
<b>8</b>	23	08YQ-18-8-220-100N Gas Spring	1
	E	Lock nut (galvanized) M8	2
	D	Flat washer (galvanized) $\Phi 8$	2

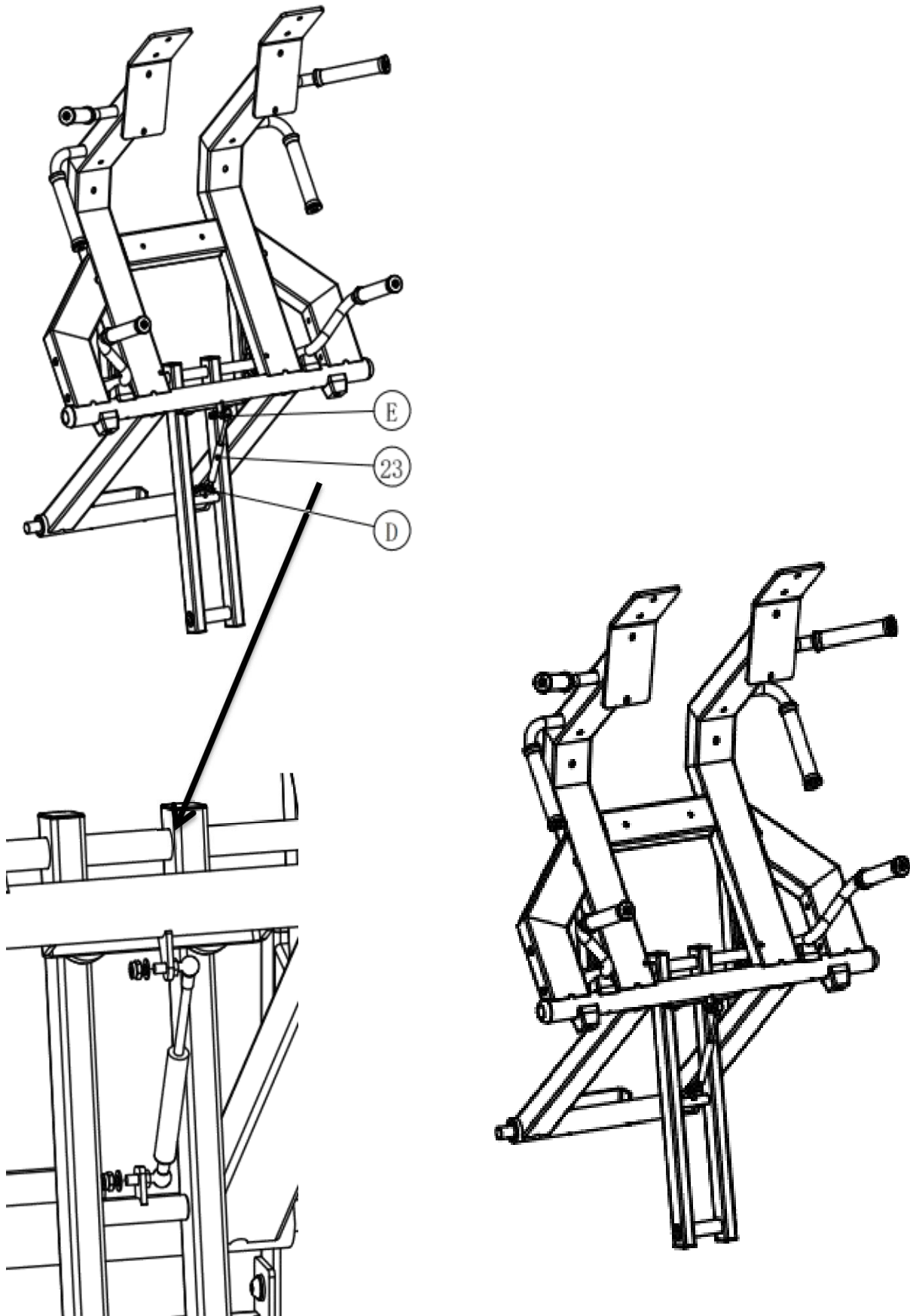

# Assembly steps

Step	Item NO	Name	Qty
9	L	Lock nut (galvanized) M10	4
	A	Flat washer (galvanized) $\Phi 10$	8
	M	Hexagon socket head screw (half-thread galvanized) M10X130	4
	24	UCFL205 bearing seat	2

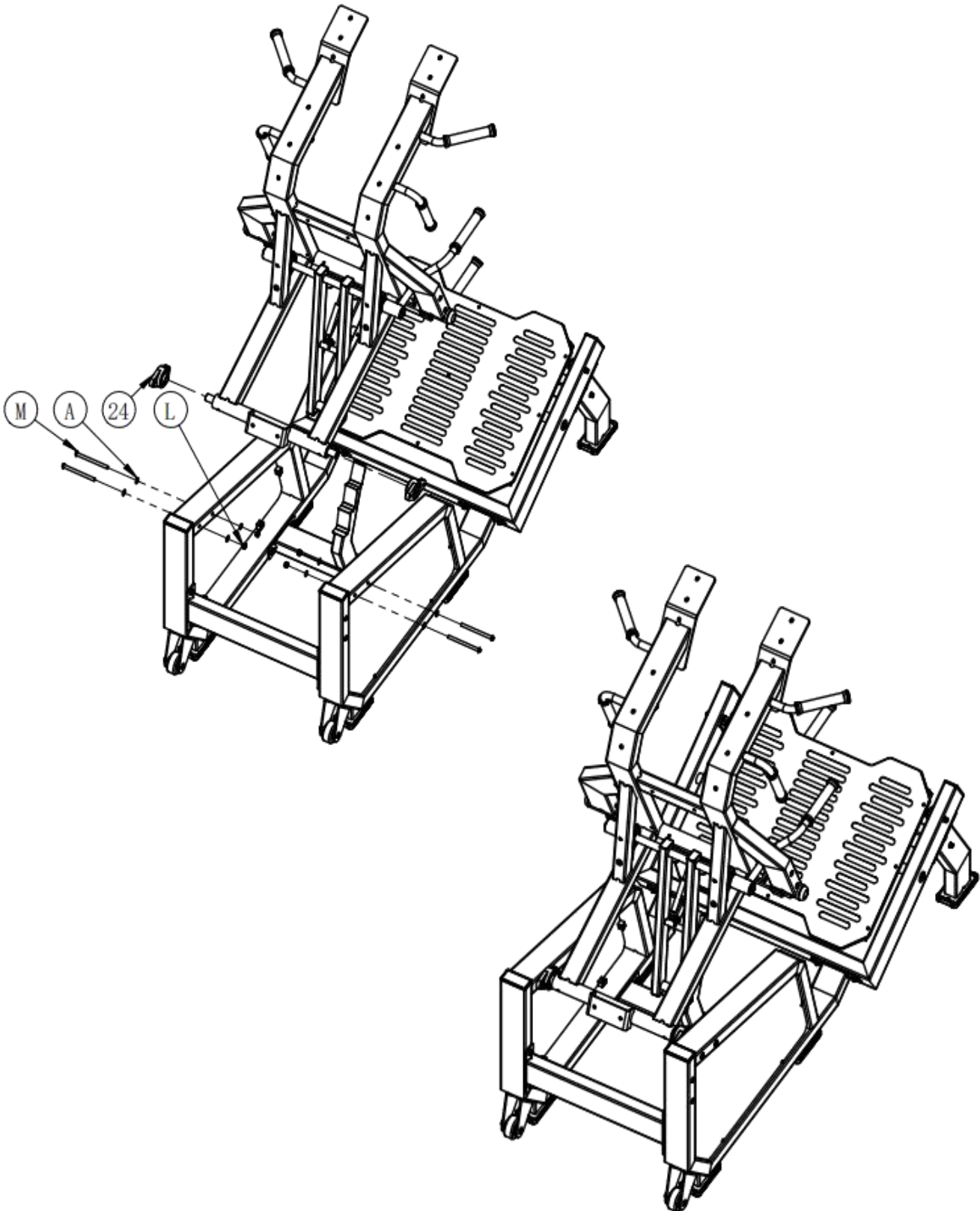

# Assembly steps

Step	Item NO	Name	Qty
10	25	5066-0009 Large backrest	1
	N	Hexagon socket head screw (half-thread galvanized) M8X70	4
	D	Flat washer (galvanized) $\Phi 8$	4

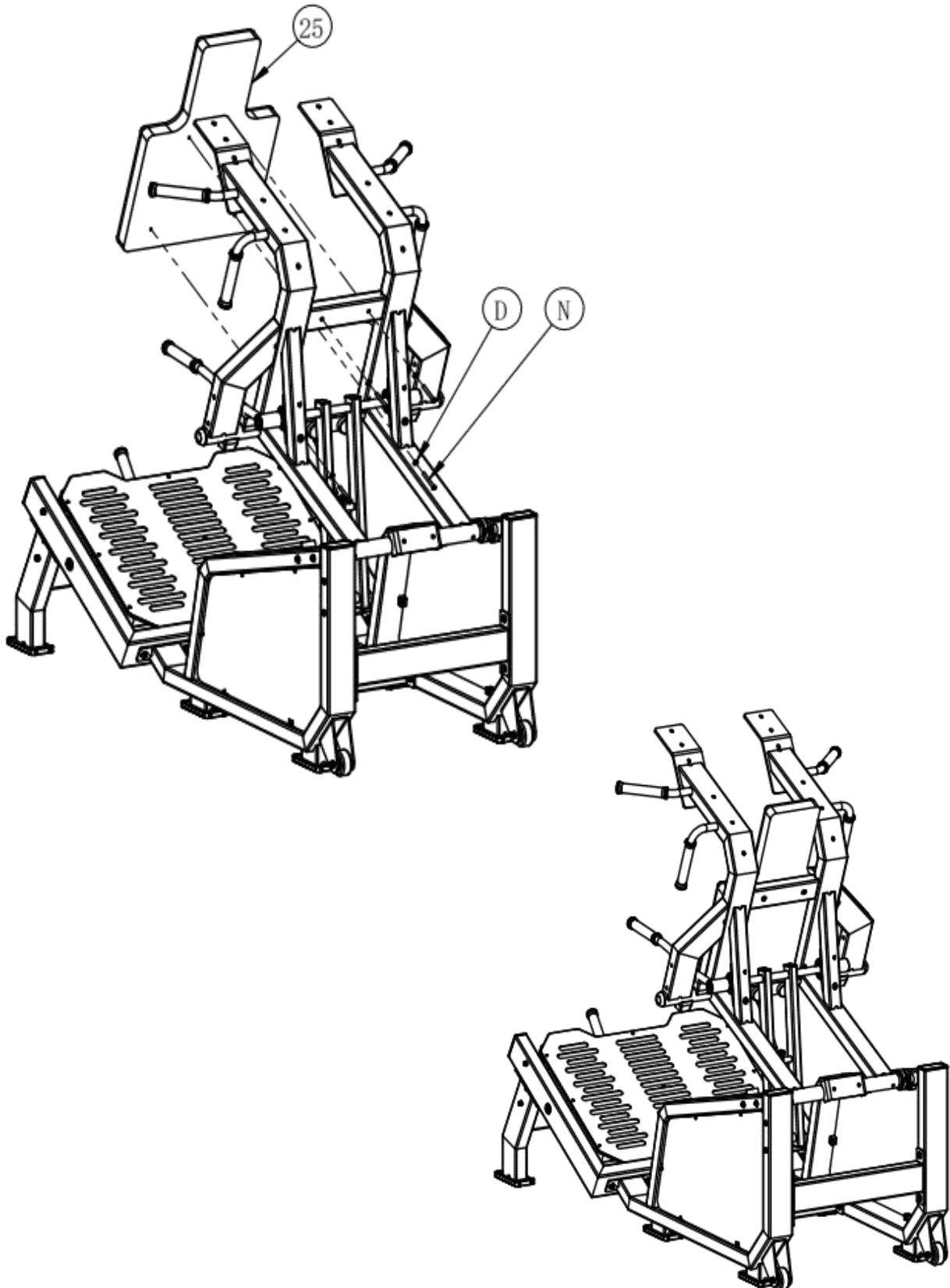



# Assembly steps

Step	Item NO	Name	Qty
11	26	5066-0007 Bend Shoulder Pad	2
	D	Flat washer (galvanized) $\Phi 8$	8
	O	Hexagon socket head screw (galvanized) M8X25	8

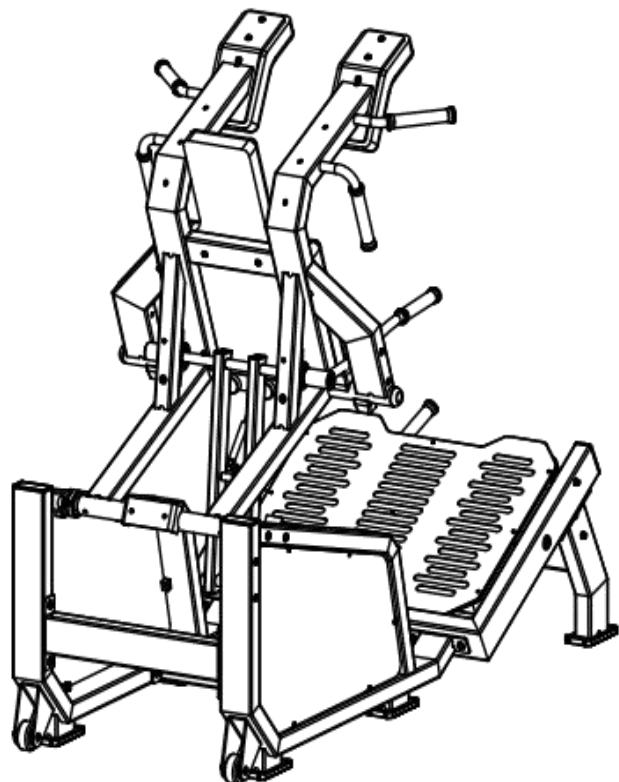
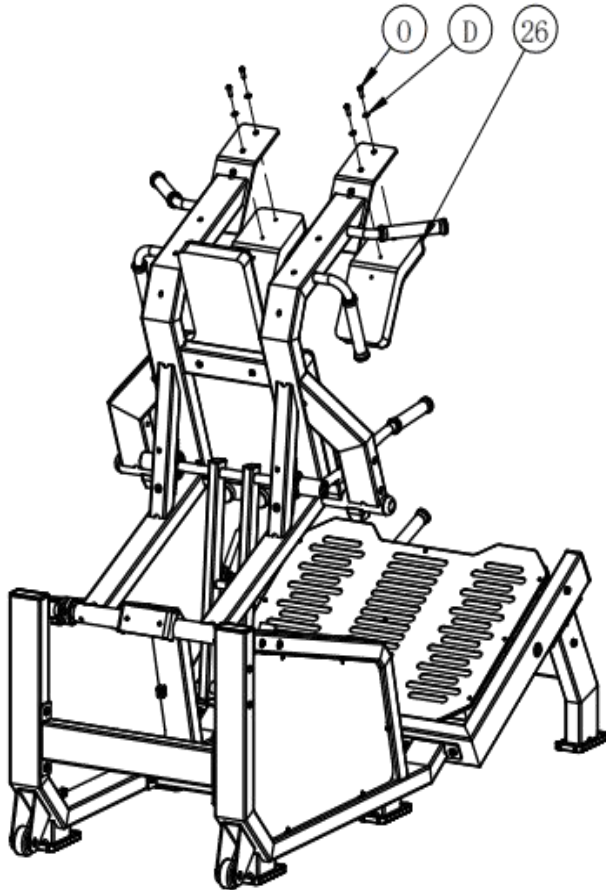

# Assembly steps

Step	Item NO	Name	Qty
<b>12</b>	27	5066-0008 Shoulder pad	2
	D	Flat washer (galvanized) $\Phi 8$	6
	N	Hexagon socket head screw (half-thread galvanized) M8X70	6

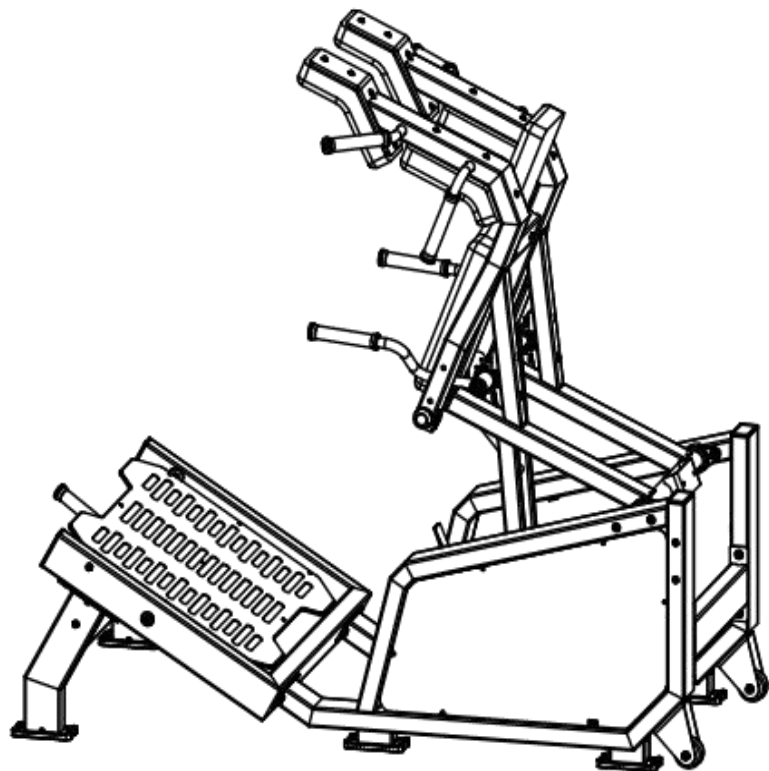
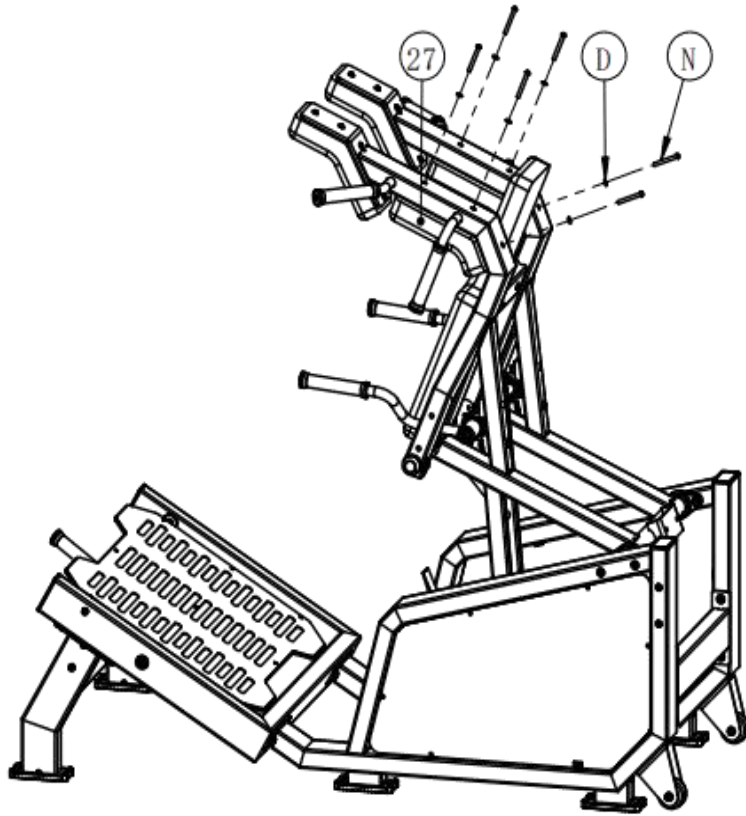



# Assembly steps

Step	Item NO	Name	Qty
13	28	5065-0900 Barbell Plate Set	2
	29	04-8101-1200 Barbell Plate Set	2
	A	Flat washer (galvanized) $\Phi 10$	12
	B	Flat head screw M10X30	4
	P	Hexagon socket head screw (half-thread galvanized) M10X120	4
	L	Lock nut (galvanized) M10	4

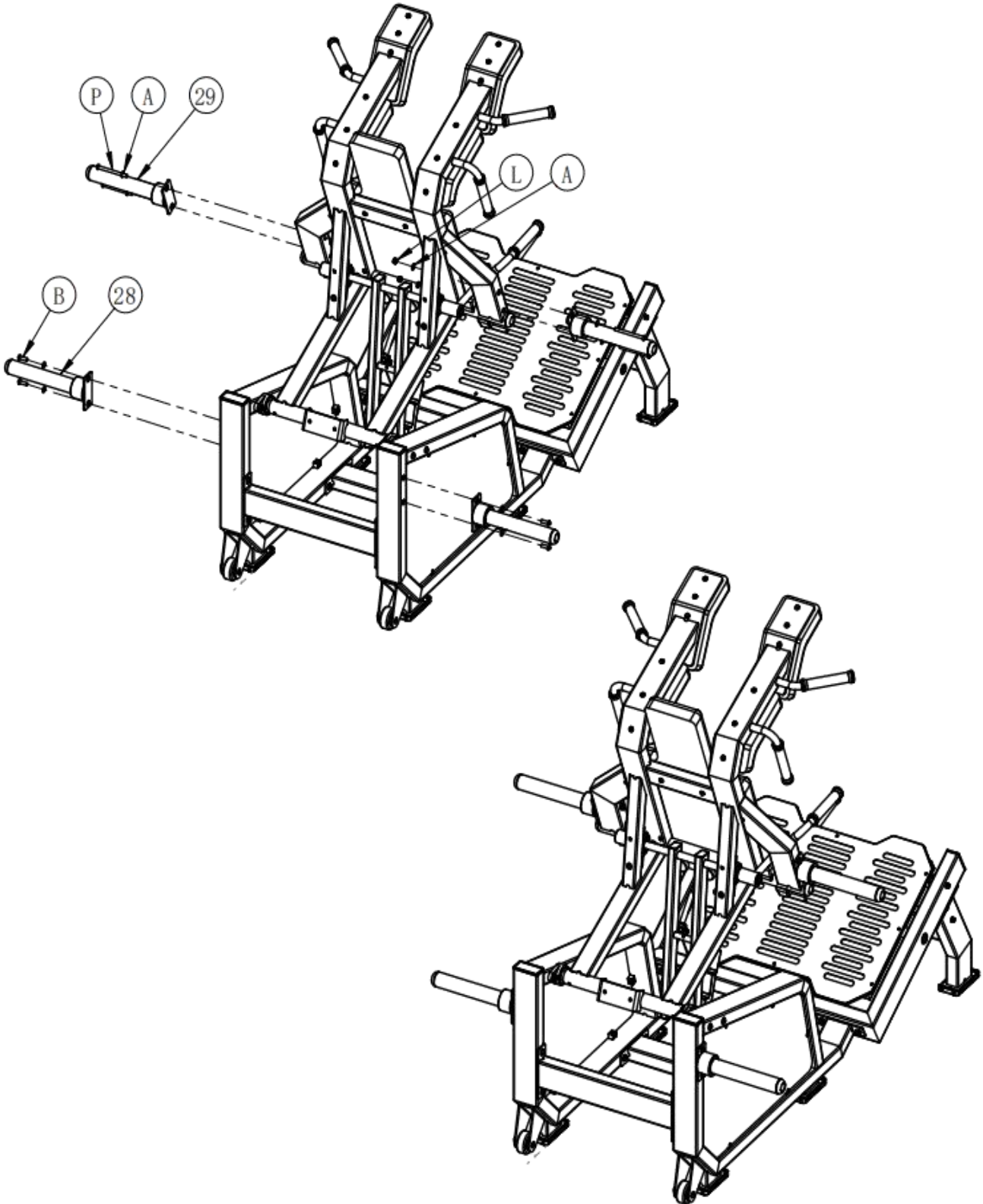

# Assembly steps

Step	Item NO	Name	Qty
<b>14</b>	30	5066-12S Barrel Assembly	1
	31	Butterfly Clip	3
	A	Flat washer (galvanized) $\Phi 10$	4
	Q	Hexagon socket head screw (galvanized) M10X25	2
	L	Lock nut (galvanized) M10	2

