

MASTER

Kabelmaskin: 68-803066

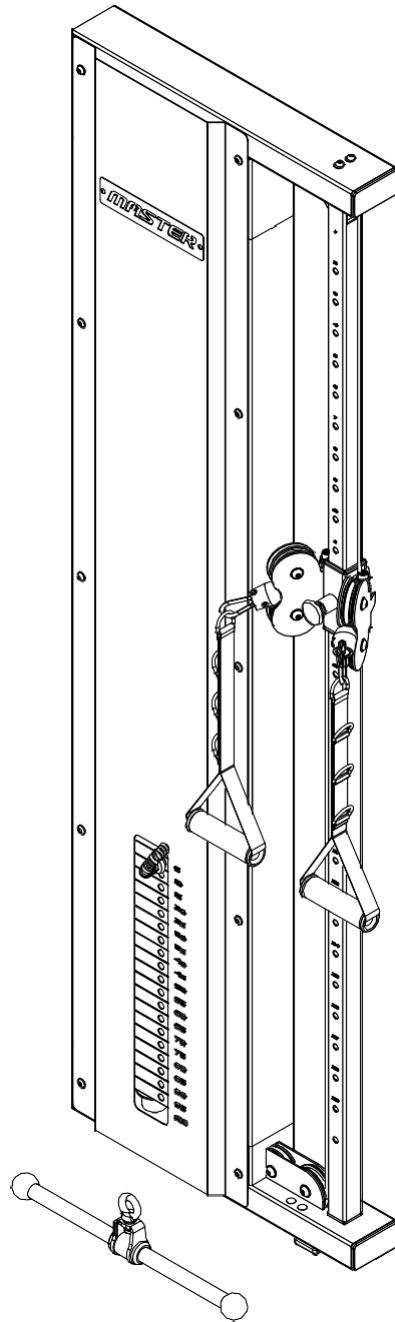

Generalagent: Vartex AB – Batterivägen 14

Varberg – Sweden – www.masterfitness.se

PART LIST

NO.	DESCRIPTION	QTY		NO.	DESCRIPTION	QTY
1	TOP BEAM	1		19	HOOK	2
2	COLUMN	2		20	ALLEN BOLT M10*30	5SET
3	BOTTOM FRAME	1		21	SOCKET CAP BOLT M10*70	1
4	UPRIGHT FRAME	1		22	SOCKET CAP BOLT M10*115	2
5	COVER	1		23	ALLEN BOLT M8*10	28
6	GUIDE ROD	2		24	BOLT M10*65	2
7	SELECTOR SHARFT	1		25	ALLEN BOLT M8*16	8
8	UPPER SLIDE BLOCK	1		26	ALLEN BOLT M8*60	2
9	DOUBLE PULLEY BLOCK	2		27	ALLEN BOLT M10*45	6
10	PLATE	4		28	ALLEN BOLT M12*60	1
11	PULLEY BLOCK	1		29	BIG WASHER 8	5
12	RUBBER BUFFER	2		30	WASHER 8	38
13	PIN	1		31	WASHER 10	23
14	TOP WEIGHT PLATE	1		32	LOCK NUT M10	8
15	HEAVY WEIGHT PLATE	19		33	NUT M12	2
16	HANDLE	1SET		34	EXPANSION BOLT	4SET
17	PULLEY - \varnothing 70	10		35	ROUND PLUG	4
18	PULLEY - \varnothing 90	1		A	CABLE	1
				36	SHIVER BAR	1

Tips för enkel montering:

Börja med att lägga ut alla ramdelarna på golvet, montera del 8 och 9 på stolpen nr 4. Montera därefter linhjulen på del 9 samt börja att dra wiren från dessa linhjul. Wiren kan man sedan dra igenom ramen – trots att samtliga ramdelar inte är hopskruvade. Efterhand som wiren kommer igenom ramdelarna så monteras övriga linhjul samt ramdelarna skruvas samman. Efter detta kan ramen resas upp samt väggfästena monteras.

Montera kabelmaskinen mot väggen och efter det monteras gummidämpare samt del 6 och alla viktskivor. Slutmontera de sista linhjulen samt skruva på huvudet på wiren.

Till sist montera del 5.





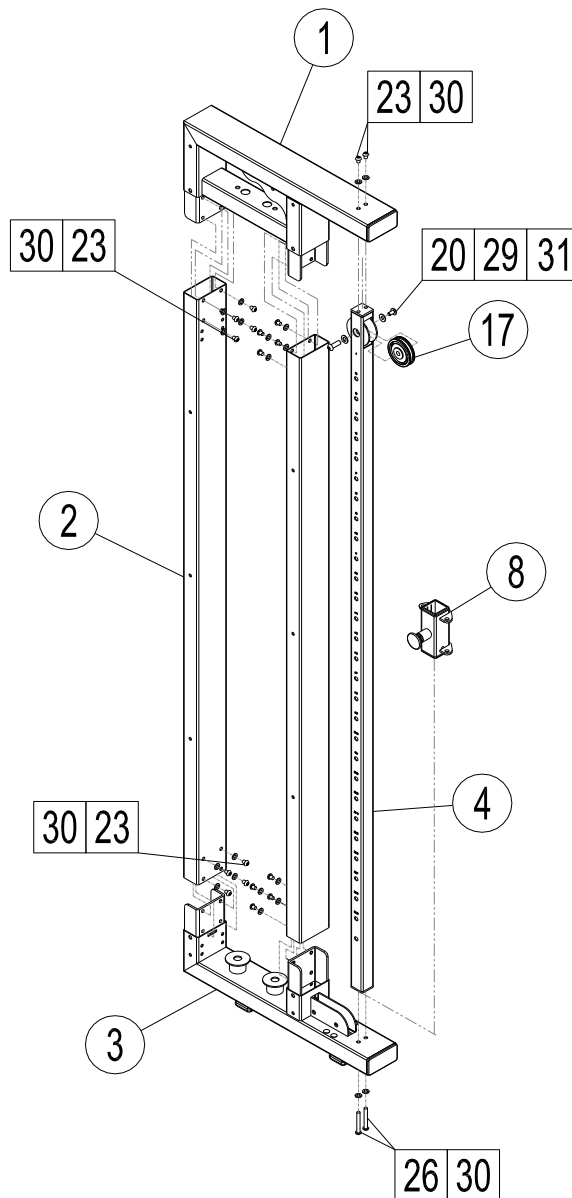

Lycka till med träningen.

ASSEMBLY STEPS

STEP 01



NOTE: Install #17 and #8 first.

20#		M10*30	Qty:1	29#		big 8	Qty:1
23#		M8*10	Qty:18	30#		8	Qty:20
26#		M8*60	Qty:2	31#		10	Qty:1

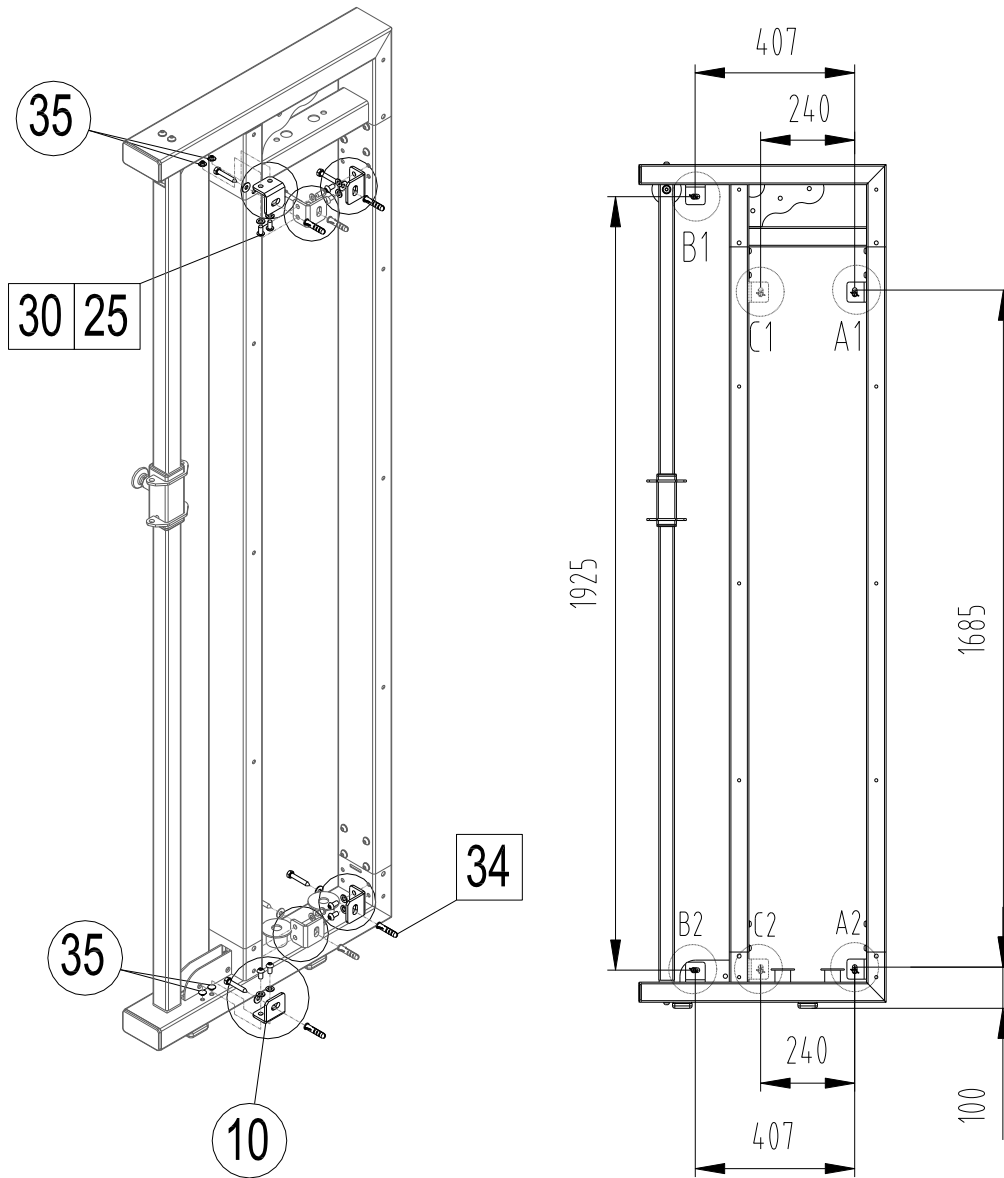

STEP 02



Method 1: A1-A2-C1-C2





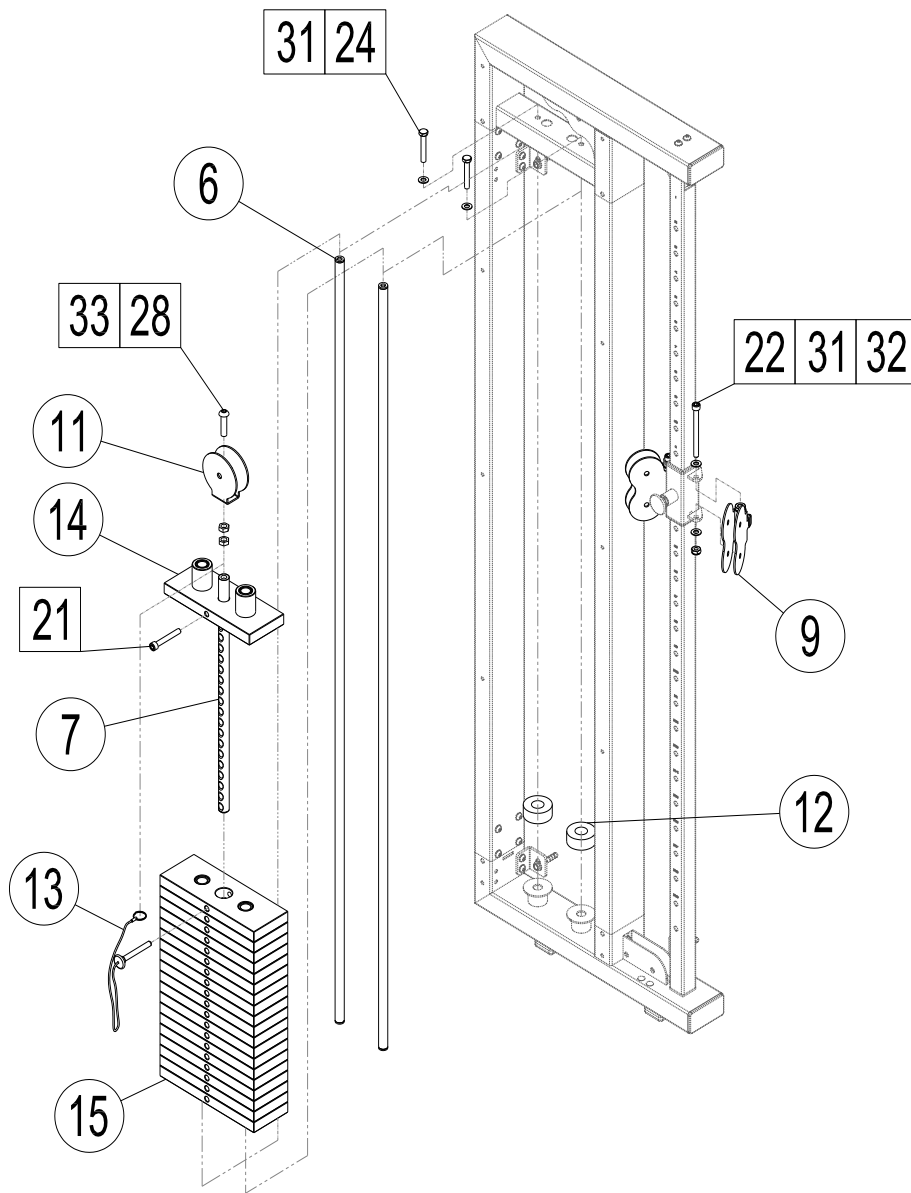

Method 2: A1-A2-B1-B2

NOTE: (#35 has been installed on #1, when using method 2,remove #35)

25#		M8*16	Qty:8
30#		8	Qty:8
34#		M8	Qty:4





STEP 03

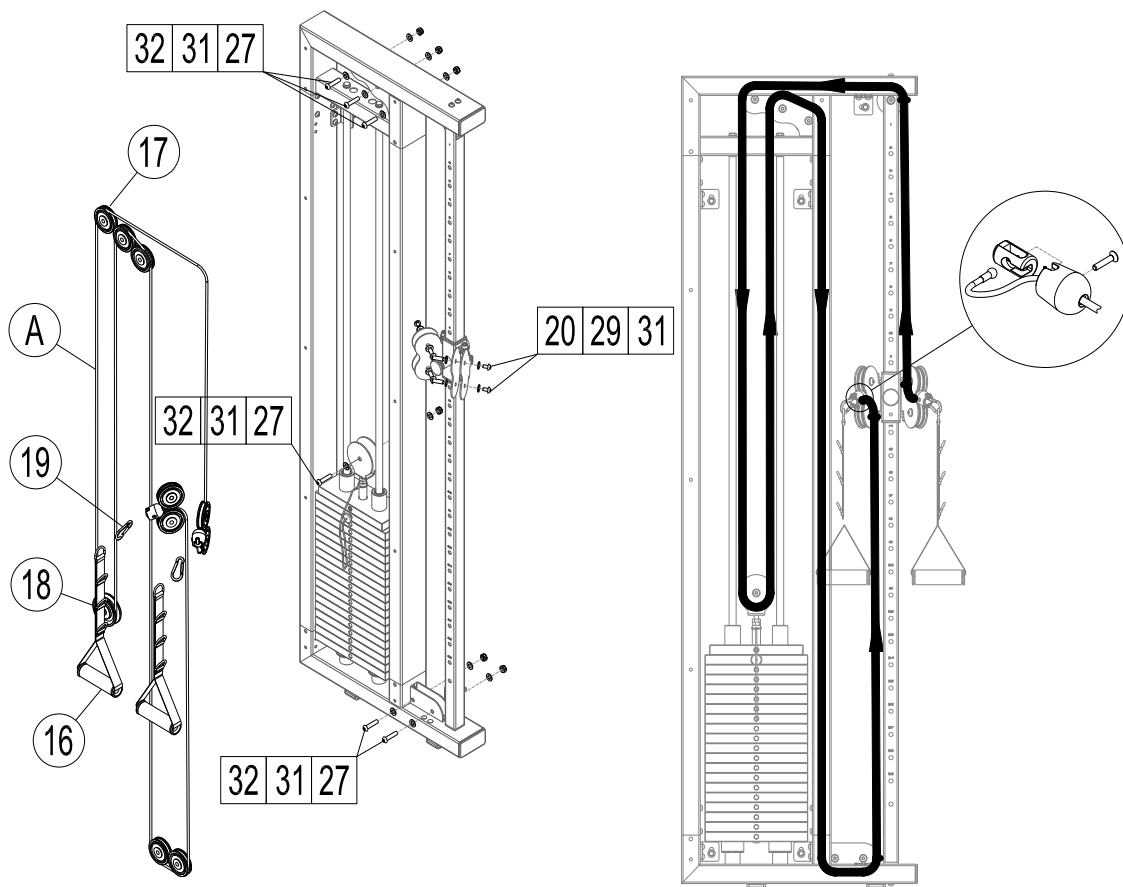

21#		M10*70	Qty:1	31#		10	Qty:6
22#		M10*115	Qty:2	32#		M10	Qty:2
24#		M10*65	Qty:2	33#		12	Qty:2
28#		M12*60	Qty:1				



STEP 04

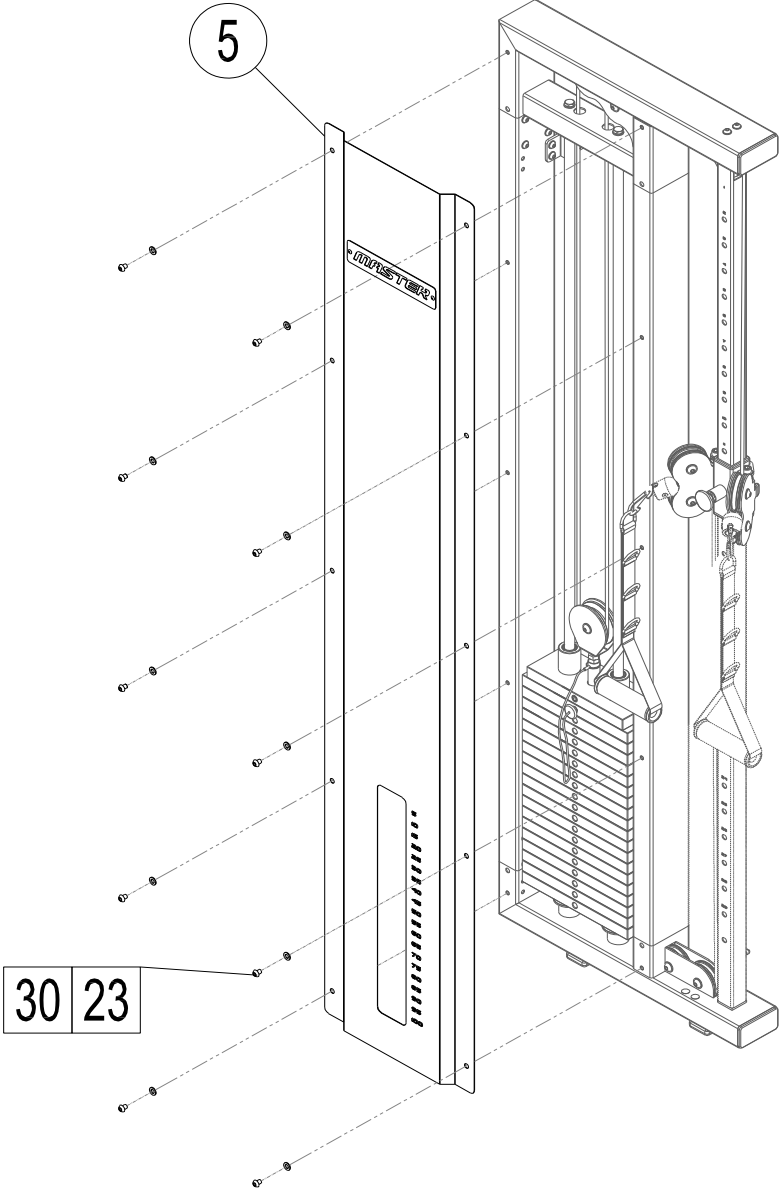

20#		M10*30	Qty:4
27#		M10*45	Qty:6
29#		big 8	Qty:4
31#		10	Qty:16
32#		M10	Qty:6

STEP 05



23#		M8*10	Qty:10
30#		8	Qty:10